

SAILOR 500/250 FleetBroadband Including 19" Rack Version



SAILOR[®] 500 FleetBroadband
SAILOR[®] 250 FleetBroadband
Including 19" Rack Version

Installation manual

Document number: 98-125646-F

Release date: July 1, 2010

Disclaimer

Any responsibility or liability for loss or damage in connection with the use of this product and the accompanying documentation is disclaimed by Thrane & Thrane. The information in this manual is provided for information purposes only, is subject to change without notice and may contain errors or inaccuracies. Manuals issued by Thrane & Thrane are periodically revised and updated. Anyone relying on this information should acquire the most current version e.g. from <http://www.thrane.com> or from the distributor. Thrane & Thrane is not responsible for the content or accuracy of any translations or reproductions, in whole or in part, of this manual from any other source.

Copyright © 2010 Thrane & Thrane A/S. All rights reserved.

Trademark acknowledgements

- **Thrane & Thrane** is a registered trademark of Thrane & Thrane A/S in the European Union and the United States.
- **SAILOR** is a registered trademark of Thrane & Thrane A/S in the European Union, the United States and other countries.
- **Windows** and **Outlook** are registered trademarks of Microsoft Corporation in the United States and other countries.
- **Inmarsat** is a registered trademark of International Maritime Satellite Organisation (IMSO) and is licensed by IMSO to Inmarsat Limited and Inmarsat Ventures plc.
- Inmarsat's product names are trademarks or registered trademarks of Inmarsat.
- Other product and company names mentioned in this manual may be trademarks or trade names of their respective owners.

Company web site

www.thrane.com

Safety summary

The following general safety precautions must be observed during all phases of operation, service and repair of this equipment. Failure to comply with these precautions or with specific warnings elsewhere in this manual violates safety standards of design, manufacture and intended use of the equipment. Thrane & Thrane A/S assumes no liability for the customer's failure to comply with these requirements.

Observe marked areas

Under extreme heat conditions do not touch areas of the terminal or antenna that are marked with this symbol, as it may result in injury.



Microwave radiation hazards

During transmission the antenna in this system radiates Microwave Power. This radiation may be hazardous to humans close to the antenna. During transmission, make sure that nobody gets closer than the recommended minimum safety distance.

On the **SAILOR 500 FleetBroadband**, the minimum safety distance to the antenna panel on the focal line is 1.3 m, based on a radiation level of 10 W/m^2 . The radiation level is 100 W/m^2 at a distance of 0.4 m from the antenna panel. Refer to the drawing on the next page.



On the **SAILOR 250 FleetBroadband**, the minimum safety distance to the antenna panel on the focal line is 0.6 m, based on a radiation level of 10 W/m^2 . The radiation level is 100 W/m^2 at a distance of 0.2 m from the antenna panel. Refer to the drawing on the next page.



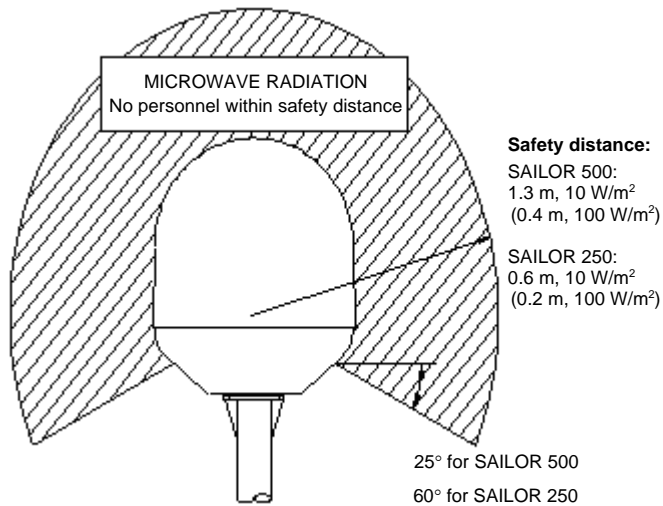

Distance to other equipment

Do not move the antenna closer to radars than the minimum safe distance specified in the installation manual - it may cause damage to the antenna.

Compass Safe Distance:

SAILOR FleetBroadband Terminal: min. 0.3 m.
 SAILOR 500 FleetBroadband antenna: min. 1.0 m
 SAILOR 250 FleetBroadband antenna: min. 1.1 m

Service

User access to the interior of the terminal is prohibited. Only a technician authorized by Thrane & Thrane A/S may perform service - failure to comply with this rule will void the warranty. Access to the interior of the antenna is allowed, but only for replacement of certain modules - as described in the Installation manual. General service may only be performed by a technician authorized by Thrane & Thrane A/S.

Do not service or adjust alone

Do not attempt internal service or adjustments unless another person, capable of rendering first aid resuscitation, is present.

Grounding, cables and connections

To minimize shock hazard, the equipment chassis and cabinet must be connected to an electrical ground. The terminal must be grounded to the ship. For further grounding information refer to the Installation manual.

Do not extend the cables beyond the lengths specified for the equipment. The cable between the terminal and antenna can be extended if it complies with the specified data concerning cable losses etc.

All cables for the SAILOR FleetBroadband system are shielded and should not be affected by magnetic fields. However, try to avoid running cables parallel to AC wiring as it might cause malfunction of the equipment.

Power supply

The voltage range is 10.5 - 32 V DC; 14 A - 5.5 A. It is recommended that the voltage is provided by the 24 V DC bus on the ship. Be aware of high start-up peak current: 20 A@24 V, 5 ms.

If a 24 V DC power bus is not available, an external 115/230 VAC to 24 V DC power supply can be used.

Do not operate in an explosive atmosphere

Do not operate the equipment in the presence of flammable gases or fumes. Operation of any electrical equipment in such an environment constitutes a definite safety hazard.

Keep away from live circuits

Operating personnel must not remove equipment covers. Component replacement and internal adjustment must be made by qualified maintenance personnel. Do not replace components with the power cable connected. Under certain conditions, dangerous voltages may exist even with the power cable removed. To avoid injuries, always disconnect power and discharge circuits before touching them.

Failure to comply with the rules above will void the warranty!

About the manual

Intended readers

This is an installation manual for the SAILOR 500 FleetBroadband and the SAILOR 250 FleetBroadband systems, intended for installers of the system and service personnel. Personnel installing or servicing the system must be properly trained and authorized by Thrane & Thrane. It is important that you observe all safety requirements listed in the beginning of this manual, and install the system according to the guidelines in this manual.

Manual overview

Note that this manual does not cover general use of the system nor does it cover how to use the IP handset that comes with the system. For this information, refer to the user manual for this system and the user manual for the IP handset, both listed in the next section.

This manual has the following chapters:

- **System units** contains a short description of each main unit in the system.
- **Installing the system** describes where to place the system units, how to mount them, special considerations for grounding, distance to other equipment etc.
- **Connecting power** explains how to connect the terminal to power and gives recommendations for cables.
- **Hardware interfaces** describes each interface on the terminal and shows pin-out for the connectors.
- **Starting up the system** explains how to insert the SIM card, power up the system and enter the PIN. It also gives a short overview of how to use the system.
- **Service and repair** describes how to replace modules for service.

-
- **Troubleshooting** describes the function of the Reset button and the light indicators on the terminal. It also describes event messages that may appear in the web interface.

Related documents

The below list shows the documents related to this manual and to the SAILOR 500 FleetBroadband and SAILOR 250 FleetBroadband systems.

Title and description	Document number
SAILOR 500 FleetBroadband SAILOR 250 FleetBroadband Including 19" Rack Version User Manual Explains how to set up and use the SAILOR FleetBroadband systems.	98-125645
SAILOR 500/250 FleetBroadband Quick Guide A short guide to the most important functions of the SAILOR FleetBroadband systems.	98-125647
Thrane IP Handset, User Manual Explains the features and functions of the Thrane IP Handset. The IP handset works as a standard IP handset, but also serves as a user interface for the SAILOR FleetBroadband systems.	98-126059

Typography

In this manual, typography is used as indicated below:

Bold is used for the following purposes:

- To emphasize words.
Example: “Do **not** touch the antenna”.
- To indicate what the user should select in the user interface.
Example: “Select **SETTINGS > LAN**”.

Italic is used to emphasize the paragraph title in cross-references.

Example: “For further information, see *Connecting Cables* on page...”.

Table of contents

	Safety summary	iii
	About the manual	vi
Chapter 1	System units	
	1.1 Introduction	1
	1.2 SAILOR FleetBroadband terminal	1
	1.3 SAILOR 500 FleetBroadband antenna	3
	1.4 SAILOR 250 FleetBroadband antenna	4
	1.5 Thrane IP Handset & Cradle	5
Chapter 2	Installing the system	
	2.1 Unpacking	7
	2.2 Placing the antenna	8
	2.3 Installing the antenna	23
	2.4 Placing the terminal	30
	2.5 Installing the SAILOR FleetBroadband terminal	33
	2.6 Installing the 19" Rack Terminal	42
Chapter 3	Connecting power	
	3.1 Power source	47
	3.2 Power cable selection	48
	3.3 Connecting power	54
Chapter 4	Hardware interfaces	
	4.1 The connector panel	59

4.2	Antenna interface on terminal	60
4.3	DC power input	61
4.4	Ground stud	63
4.5	19" rack version only: Terminal block	64
4.6	Analog Phone/Fax interface	65
4.7	ISDN interface	66
4.8	LAN interface	68
4.9	Discrete I/O interface	71
4.10	L-Band interface	76

Chapter 5 Starting up the system

5.1	Using the SIM card	77
5.2	Powering the system	79
5.3	Entering the SIM PIN for the terminal	82
5.4	Operating the system	85

Chapter 6 Service and repair

6.1	Introduction	87
6.2	Replacing modules in TT-3052A antenna	87
6.3	Replacing modules in TT-3052B/C antenna	97

Chapter 7 Troubleshooting

7.1	Reset button	111
7.2	Status signaling	114
7.3	Logging of events	120

App. A	Part numbers	
	A.1 System units	121
	A.2 Spare parts	122
App. B	Technical specifications	
	B.1 Overview	123
	B.2 SAILOR 500 FleetBroadband antenna	124
	B.3 SAILOR 250 FleetBroadband antenna	133
	B.4 Minimum distance to transmitters	138
	B.5 SAILOR FleetBroadband terminal	139
App. C	Grounding and RF protection	
	C.1 Why is grounding required?	149
	C.2 About marine DC systems	150
	C.3 About marine grounding	152
	C.4 Grounding Recommendations	153
	C.5 Alternative grounding for steel hulls	155
	C.6 Alternative grounding for aluminum hulls	157
	C.7 Alternative grounding for fiberglass hulls	159
	C.8 Alternative grounding for timber hulls	161
	C.9 Separate ground cable	163
	C.10 RF interference	166
	C.11 Electrostatic Discharge	166
Glossary	167
Index	173

System units

1.1 Introduction

The basic system consists of three units: The terminal, the antenna and the IP handset with cradle.

There are two different types of antennas, depending on whether you have a SAILOR 500 FleetBroadband system or a SAILOR 250 FleetBroadband system.

1.2 SAILOR FleetBroadband terminal

The terminal is the central unit in the system. It contains all user interfaces and handles all communication between the BGAN antenna and the local communication units (phones, computers etc.).

The terminal comes in two versions, one designed for wall or desktop installation, and one designed for installation in a 19" rack.

Below is the terminal for wall or desktop installation.



Below is the 19" rack version of the terminal.



The terminal supplies 18-29 V DC to the antenna through a single coaxial cable.

The DC input for the terminal is designed for both 24 V DC and 12 V DC power supply.

1.3 SAILOR 500 FleetBroadband antenna

The SAILOR 500 FleetBroadband antenna is a mechanical tracking antenna, consisting of a stabilized antenna with RF-unit, antenna control unit and GPS antenna. The antenna is dedicated to the Inmarsat BGAN (Broadband Global Area Network) system. All communication between the antenna and terminal passes through a single coaxial cable. The antenna unit TT-3052AB/ is protected by a fiberglass radome. The antenna unit TT-3052C is protected by a Telene radome.

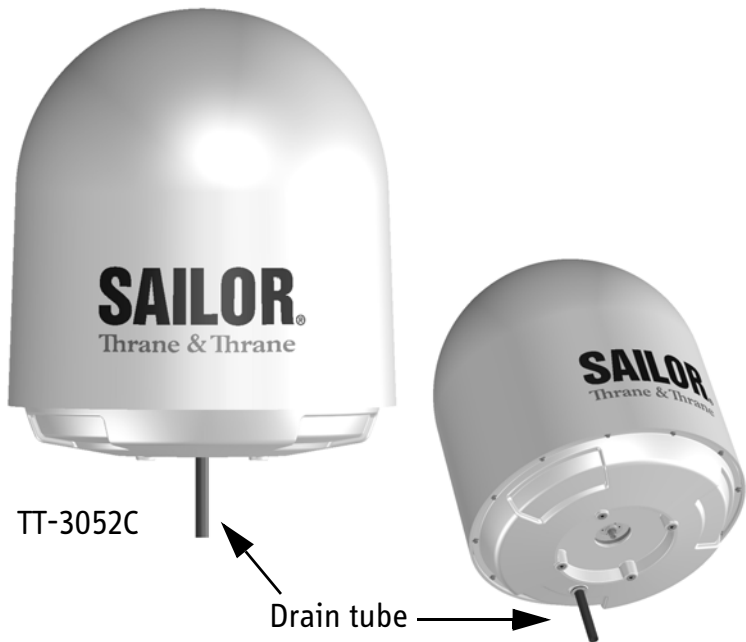

1.4 SAILOR 250 FleetBroadband antenna

The SAILOR 250 FleetBroadband antenna is a BGAN mechanical tracking antenna. All communication between the antenna and terminal passes through a single coaxial cable. The antenna unit is protected by a thermo-plastic radome.



1.5 Thrane IP Handset & Cradle



1.5.1 Thrane IP Handset

Besides the normal functions of an IP handset, the Thrane IP handset also provides a user interface for the SAILOR FleetBroadband system. The IP handset connects to the LAN interface of the terminal, and is power supplied with Power over Ethernet (PoE) through the LAN interface.

For further information on the IP handset, refer to the user manual for the Thrane IP Handset.

1.5.2 Thrane IP Cradle

The IP cradle serves as a holder for the IP handset. It is power supplied from the terminal using Power over Ethernet (PoE). The cradle connects to the handset with a coil cord and to the terminal with a standard LAN cable.

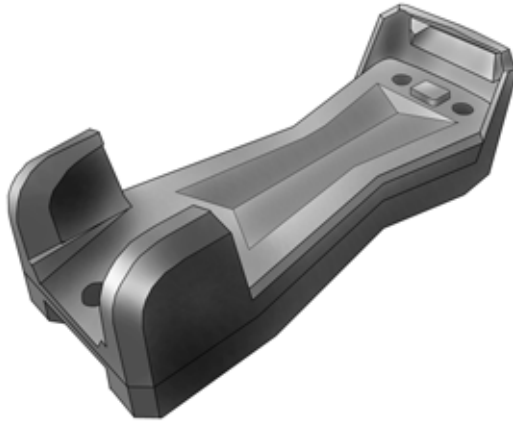

Installing the system

2.1 Unpacking

Unpack your SAILOR FleetBroadband system and check that the following items are present:

- TT-3738A SAILOR FleetBroadband terminal or TT-3738A-T19 SAILOR FleetBroadband 19" Rack Terminal
- TT-3052A/B/C SAILOR 500 FleetBroadband antenna or TT-3050A SAILOR 250 FleetBroadband antenna
- TT-3670A Thrane IP Handset & Cradle, wired
- Basic cable support kit including an I/O connector, or for 19" rack version: Strain Relief Bracket
- Power cable
- Antenna cable
- LAN cable
- User manual
- Installation manual (this manual)
- Quick guide

Inspect all units and parts for possible transport damage.

Note

For information on how to install the IP handset and cradle, refer to the user manual for the handset.

2.2 Placing the antenna

2.2.1 Obstructions

The antenna rotates 360° and down to -25° for the SAILOR 500 FleetBroadband and -60° for the SAILOR 250 FleetBroadband in pitch and roll, to allow for continuous pointing even in heavy sea conditions. Any obstructions within this volume can cause signal degradation.

The amount of degradation depends on the size of the obstruction and the distance from the antenna. As a rule of thumb any obstruction that covers an angle of less than 3° at the antenna has limited effect. The table below gives a guideline for obstruction sizes that will cause limited degradation.

Distance of Obstruction	Size of Obstruction
3 m	16 cm
5 m	26 cm
10 m	52 cm
20 m	104 cm

2.2.2 Radiation hazard

The SAILOR 500 FleetBroadband antenna radiates up to 22 dBW EIRP. This translates to a minimum safety distance of 1.3 m from the antenna while it is transmitting, based on a radiation level of 10 mW/cm^2 .

The SAILOR 250 FleetBroadband antenna radiates 16.1 dBW EIRP. This translates to a minimum safety distance of 0.6 m from the antenna while it is transmitting, based on a radiation level of 10 mW/cm^2 .

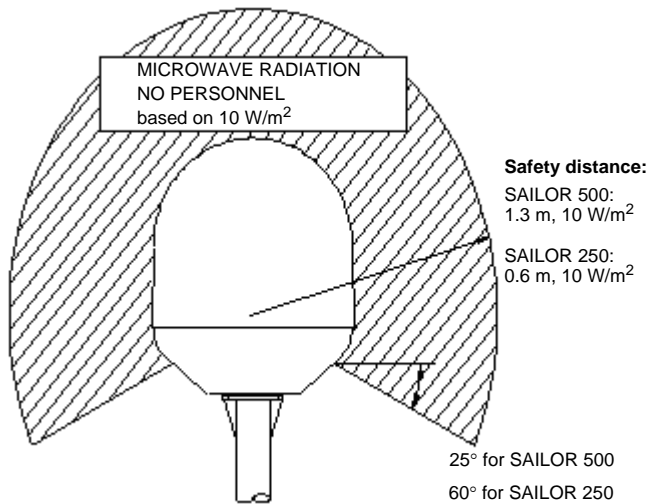

For higher radiation levels, see the table below.

Radiation level	Safety distance	
	SAILOR 500 FleetBroadband	SAILOR 250 FleetBroadband
100 W/m^2	0.4 m	0.2 m
10 W/m^2	1.3 m	0.6 m

2.2.3 Interference

Overview

The antenna must be mounted as far away as possible from the ship's radar and high power radio transmitters (including other Inmarsat based systems), because they may compromise the antenna performance. RF emission from radars might actually damage the antenna.

The SAILOR FleetBroadband antenna itself may also interfere with other radio systems. Especially other Inmarsat systems and GPS receivers with poor frequency discrimination are vulnerable to the radiation generated by the SAILOR FleetBroadband antennas.

Radar

It is difficult to give exact guidelines for the minimum distance between a radar and the antenna because radar power, radiation pattern, frequency and pulse length/shape vary from radar to radar. Further, the antenna is typically placed in the near field of the radar antenna and reflections from masts, decks and other items in the vicinity of the radar are different from ship to ship.

However, it is possible to give a few guidelines:

Since a radar radiates a fan beam with a horizontal beam width of a few degrees and a vertical beam width of up to $\pm 15^\circ$, the worst interference can be avoided by mounting the antenna at a different level – meaning that the antenna is installed minimum 15° above or below the radar antenna. Due to near field effects the benefit of this vertical separation could be reduced at short distances (below approximately 10 m) between radar antenna and the SAILOR FleetBroadband antenna. Therefore it is recommended to ensure as much vertical separation as possible when the SAILOR FleetBroadband antenna has to be placed close to a radar antenna.

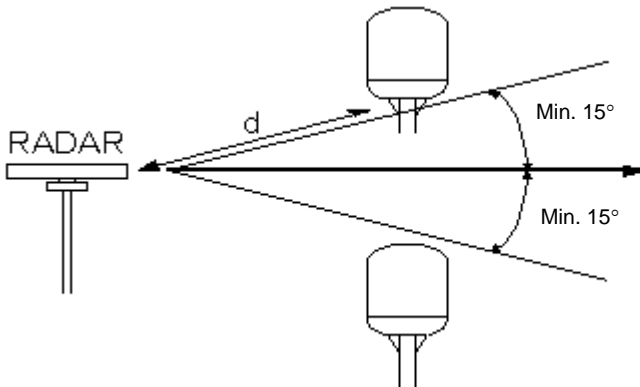

Radar distance

The minimum acceptable separation (d min.) between a radar and the antenna is determined by the radar wavelength/frequency and the power emitted by the radar. The tables below show some “rule of thumb” minimum separation distances as a function of radar power at X and S band. If the d min. separation listed below is applied, antenna damage is normally avoided.

“d min.” is defined as the shortest distance between the radar antenna (in any position) and the surface of the SAILOR FleetBroadband antenna.

X-band (~ 3 cm / 10 GHz) damage distance				
Radar power	SAILOR 500 FleetBroadband		SAILOR 250 FleetBroadband	
	d min. at 15° vertical separation	d min. at 60° vertical separation	d min. at 15° vertical separation	d min. at 60° vertical separation
0 - 10 kW	0.8 m	0.4 m	0.8 m	0.4 m
30 kW	2.4 m	1.2 m	2.4 m	1.2 m
50 kW	4.0 m	2.0 m	4.0 m	2.0 m

S-band (~ 10 cm / 3 GHz) damage distance				
Radar power	SAILOR 500 FleetBroadband		SAILOR 250 FleetBroadband	
	d min. at 15° vertical separation	d min. at 60° vertical separation	d min. at 30° vertical separation	d min. at 75° vertical separation
0 - 10 kW	0.4 m	0.2 m	0.4 m	0.2 m
30 kW	1.0 m	0.5 m	1.0 m	0.5 m
50 kW	2.0 m	1.0 m	2.0 m	1.0 m

The separation distance for C-band (4-8 GHz) radars should generally be the same as for X-band radars.

Interference

Even at distances greater than “d min.” in the previous section the radar might still be able to degrade the performance of the SAILOR FleetBroadband system.

The presence of one or more X-band radars within a radius up to 100 m could cause a minor degradation of the signal-to-noise ratio during high speed and data calls. The degradation will be most significant at high radar pulse repetition rates.

As long as receiving conditions are favorable, this limited degradation is without importance. However, if receiving conditions are poor – e.g. due to objects blocking the signal path, heavy rainfall or icing, low satellite elevation and violent ship movements – the small extra degradation due to the radar(s) could cause poor call quality. A voice call might become noisy and perhaps fail while a data connection might decrease in speed and performance.

The presences of S-band radar(s) are unlikely to cause any performance degradation – as long as the minimum distances (d min.) listed in the previous section are applied.

It is strongly recommended that interference free operation is verified experimentally before the installation is finalized.



Caution! The antenna must never be installed closer to a radar than “d min.” - even if experiments show that interference free operation can be obtained at shorter distances than “d min.” in the previous section.

Other Inmarsat systems

Recommended minimum safe distance to other Inmarsat antennas is 10 m.

GPS receivers

Good quality GPS receivers will work properly very close to the antenna - typically down to one meter outside the main beam, and down to a few meters inside the main beam. However, simple GPS receivers with poor frequency discrimination could be affected at longer range (typically 10 m). It is always recommended to test the GPS performance before the installation is finalized.

VSAT systems

For optimum performance we recommend a minimum distance of 3 meters from the BGAN antenna to VSAT antennas.

Other transmitters

See *Minimum distance to transmitters* on page 138 in Appendix B for minimum recommended distance to transmitters in the frequency range below 1000 MHz.

Other precautions

Do not place the antenna close to a funnel, as smoke deposits are corrosive. Furthermore, deposits on the radome can degrade performance.

2.2.4 Antenna mast design

Overview

The antenna mast must be designed to carry the weight of the antenna unit, which is approximately

- 16 kg for TT-3052A, 19 kg for TT-3052B or 23 kg for TT-3052C (+ the weight of the mast flange) for the SAILOR 500 FleetBroadband antenna and
- 3.9 kg (+ 1.1 kg for the mast mount kit) for the SAILOR 250 FleetBroadband antenna.

The mast must also be able to withstand onboard vibrations and wind forces up to 108 knots on the radome, even in icing conditions.

The SAILOR 500 FleetBroadband and SAILOR 250 FleetBroadband antennas use different methods for mast mounting. The following sections describe the methods separately.

SAILOR 500 FleetBroadband antenna mast flange for TT-3052A/B

1. The top of the SAILOR 500 FleetBroadband antenna mast for TT-3052A/B should be fitted with a flange with holes matching the bushings in the radome. The flange thickness must be at least 10 mm.
2. Drill a hole in the centre of the flange for the antenna cable and for drainage from the radome.
3. Mount the antenna on the flange by means of 4 M10 bolts. The length of the bolts must be such that they engage into the bushings of the radome with minimum 6 mm and maximum 12 mm.
4. Protect the cable connection against water ingress by wrapping it with self-amalgamating rubber.

For recommended dimensions of the flange, see *Outline dimensions, SAILOR 500 flange* on page 131.

Important

Avoid sharp edges where the flange is in direct contact with the radome. Round all edges as much as possible to avoid damaging the surface of the radome.

SAILOR 500 FleetBroadband antenna mast flange for TT-3052C

1. The top of the SAILOR 500 FleetBroadband antenna mast for TT-3052C should be fitted with a flange with holes matching the bushings in the radome. The flange thickness must be at least 10 mm.
2. Drill a hole in the centre of the flange for the antenna cable.
3. Mount the antenna on the flange by means of 4 M10 bolts. The length of the bolts must be such that they engage into the bushings of the radome with minimum 10 mm and maximum 25 mm.
4. Protect the cable connection against water ingress by wrapping it with self-amalgamating rubber.



For recommended dimensions of the flange, see *Outline dimensions, SAILOR 500 flange* on page 131.

Important

Avoid sharp edges where the flange is in direct contact with the radome. Round all edges as much as possible to avoid damaging the surface of the radome.

SAILOR 250 FleetBroadband antenna mast mounting

Mast mount kit:

The top of the SAILOR 250 FleetBroadband antenna mast should be fitted with the dedicated mounting kit available from Thrane & Thrane.

Assemble the mast mount kit according to the assembly instruction included with the kit.

The mast mount kit interfaces to a 1½” pipe (OD 48.3 mm). If the supplied plastic sleeve is omitted, a maximum diameter OD of 52 mm can be used.

Custom mast mounting:

For a custom mast mounting, use 4 M6 bolts (A4) in the threaded bushings on the 175.4 mm diameter circle in the bottom of the antenna (see outline drawing *SAILOR 250 FleetBroadband antenna* on page 137). The length of the bolts must be such that they engage into the bushings of the radome with min. 6 mm and max. 12 mm. No drainage hole is necessary. Drill a hole for the cable or use an angled connector.

Mast length and diameter

The placement of the antenna must ensure a rigid structural connection to the hull or structure of the ship. Parts of the ship with heavy resonant vibrations are not suitable places for the antenna.

A small platform or short mast shall provide rigid support for the antenna fastening bolts and a rigid interface to the ship.

If it is necessary to use a tall mast, use the tables on page 20 and page 21 to obtain the maximum free length of the mast. Note that these values depend on rigid antenna-ship interfaces. The cross-sectional properties and the corresponding maximum free length give a natural frequency above 30 Hz.

It is recommended to shorten the mast length as much as possible to obtain higher frequencies. Alternatively, mount stays or wires to stabilize the mast further.

TT-3052A/B

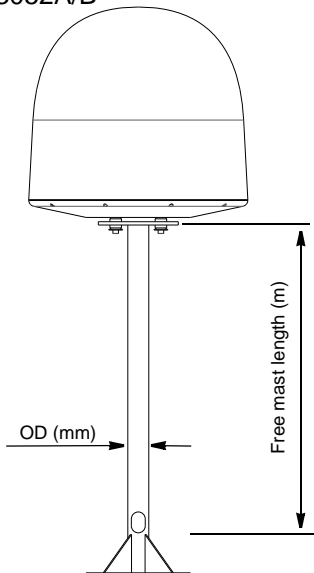

TT-3052C

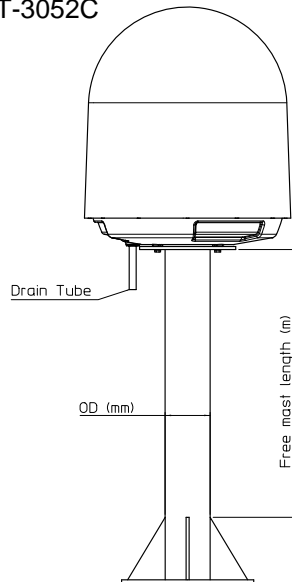

Note

The hole in the lower part of the mast is necessary for drainage and ventilation for the SAILOR 500 FleetBroadband antenna TT-3052A/B.

Make sure that there is free space below the drain tube of the TT-3052C.

Please refer to *Condensation, SAILOR 500 FleetBroadband* on page 26.

The tables in the next sections give some suggested design values for the free part of the mast (shown on the previous page).

Note

The tables list the values for **steel masts**.

For **aluminium masts**, the free mast length is reduced to 75% of the values for steel.

High masts or installations on ships with high vibration levels should be further stabilized by stays or wires from the mast flange. Also mount vibration isolators between the flange and the radome, as described in *Vibration, SAILOR 500 FleetBroadband antenna* on page 27. For SAILOR 250 FleetBroadband, the vibration isolators are included in the Mast mount kit.

Note

Stays and rigid masts can still not prevent vertical vibration if the mast is attached to a deck plate that is not rigid. Make every effort to mount the mast on a surface that is well supported by ribs. If this is not possible, provide extra deck plate propping.

SAILOR 500 FleetBroadband antenna mast length for TT-3052A/B/C

The below table shows the values for a **SAILOR 500 FleetBroadband** antenna mast without stays or wires. Note that these values are only guidelines - always consider the environment and characteristics of the ship before deciding on the mast dimensions.

OD (mm)	Wall Thickness (mm)	Weight (kg/m)	Inertia ($\times 10^6 \text{ mm}^4$)	Max. free mast length (steel), m
88.9	4.05	8.47	0.974	< 0.9
88.9	4.85	10.1	1.14	
100	5	11.7	1.69	< 1.0
101.6	5	11.9	1.77	
114.3	4.5	12.1	2.34	< 1.2
114.3	5.4	14.4	2.75	
139.7	4.85	16.1	4.68	< 1.4
139.7	5.4	17.9	5.14	
165.1	4.85	19.2	7.85	< 1.6
165.1	5.4	21.3	8.65	
200 ^a	5	24	14.6	< 2.0
200 ^a	10	46.9	27	

OD (mm)	Wall Thickness (mm)	Weight (kg/m)	Inertia ($\times 10^6 \text{ mm}^4$)	Max. free mast length (steel), m
300 ^{ab}	7.5	54.1	73.75	< 2.7
300 ^{ab}	15	105.4	136.7	

- TT-5032A/B: The diameter of the circle where the bolts are to be mounted on the antenna is $\varnothing 183.8$. Since the mast diameter is larger, you must use a tapered end on the mast, or find other means of accessing the mounting bushings.
- TT-5032C: The diameter of the circle where the bolts are to be mounted on the antenna is $\varnothing 282.8$. Since the mast diameter is larger, you must use a tapered end on the mast, or find other means of accessing the mounting bushings.

SAILOR 250 FleetBroadband antenna mast length

The below table shows the values for a **SAILOR 250 FleetBroadband** antenna mast without stays or wires. Note that these values are only guidelines - always consider the environment and characteristics of the ship before deciding on the mast dimensions.

The mast mount kit interfaces to a 1½" tube (OD 48.3 mm - absolute maximum OD 52 mm). Masts with larger diameters must be tapered and the upper part of the tube (approximately 50 mm) must have a diameter of 1½".

OD (mm)	Wall Thickness (mm)	Weight (kg/m)	Inertia ($\times 10^6 \text{ mm}^4$)	Max. free mast length (steel), m
48.3	3.25	3.61	0.117	< 0.6
48.3	4.05	4.43	0.139	
50	3.00	3.48	0.123	

OD (mm)	Wall Thickness (mm)	Weight (kg/m)	Inertia ($\times 10^6 \text{ mm}^4$)	Max. free mast length (steel), m
60.3	3.65	5.10	0.262	<0.8
60.3	4.50	6.17	0.309	
76.1	3.65	6.80	0.547	< 1.0
76.1	4.50	7.90	0.651	
88.9	4.05	8.47	0.974	< 1.1
88.9	4.85	10.10	1.140	

2.3 Installing the antenna

2.3.1 Antenna grounding

You may ground the antenna using the mounting bolts.

If the antenna cannot or should not be electrically connected directly to the mounting surface, you can use a separate grounding cable to make the connection between the antenna and the common ground to which the terminal is also connected. For example, you can connect a separate grounding cable when vibration isolators are used at the mounting bolts.

To obtain a good ground connection, the metal underneath the head of **at least** one bolt must be clean of insulating protective coating and a serrated washer should be used. After tightening the bolts we recommend that you seal the area suitably in order to avoid corrosion of the grounding point.

Use stainless steel bolts and washers.

For further grounding information read Appendix C *Grounding and RF protection* on page 149.

2.3.2 Antenna cables

Guidelines

A coaxial cable for connection between the antenna and terminal is delivered with the system. If you need a different cable, make sure that the cable meets the requirements. Preferably choose one of the cable types in *Recommended antenna cables* below.

Select a suitable area for installation of the terminal, antenna and cradle. Where the cables are exposed to mechanical wear - on deck, through bulkheads, etc. - protect the cables with steel pipes. Otherwise, follow standard procedures for cabling in ship installations.

The maximum allowed RF-loss in the antenna cable is 20 dB at 1660 MHz. This is to ensure the performance of the system.

Recommended antenna cables

The table below shows recommended cable types and maximum cable lengths for both SAILOR 500 FleetBroadband and SAILOR 250 FleetBroadband.

Cable Type	Absolute maximum length
G02232-D	6 m
RG223-D	25 m
RG214/U	50 m
S 07272B-05	95 m

Check in the data sheet from the cable supplier that both the RF-attenuation and the DC-resistance are kept within the maximum specified values:

- Antenna cable RF-attenuation at 1660 MHz: max. 20 dB incl. connector.
- Antenna cable modem-attenuation at 54 MHz: max. 4 dB.
Antenna cable modem-attenuation at 36 MHz: max. 3 dB.
- Antenna cable loop DC-resistance max: 1 Ω .

Also ensure that the specified minimum bending radius is respected. If this is not the case, the loss in the cable will increase. Check the instructions from the cable supplier.

2.3.3 Important mounting notes

Line of sight

Place the antenna with free line of sight in all directions to ensure proper reception of the satellite signal. Do not place the antenna close to large objects that may block the signal.

Water intrusion

After having connected the antenna cable to the antenna - ensure that the connector assembly is properly protected against seawater and corrosion. As a minimum, use self-amalgamating rubber.

If possible, install the radome such that direct spray of sea water is avoided.

It is recommended not to use pneumatic tools for cleaning the radome, especially at a short distance and directly at the split between top and bottom.

Note that TT-3052C has a dedicated drain tube while TT-3052A/B antennas are drained for condensation through the gasket in the bottom center. Make sure the requirements to drainage are met. See *Condensation, SAILOR 500 FleetBroadband* on page 26.

Condensation, SAILOR 500 FleetBroadband

In some cases there will be condensation inside the radome. The gasket in the bottom center of the SAILOR 500 FleetBroadband antenna TT-3052A/B is designed to lead any water away from the radome. The TT-3052C has a dedicated drain tube.

TT-3052A/B

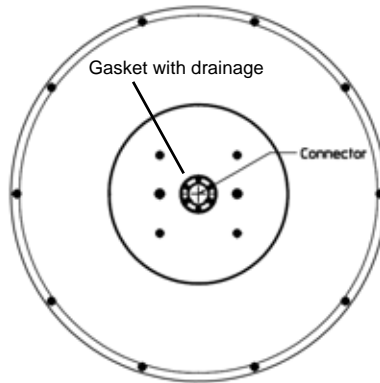

TT-3052C

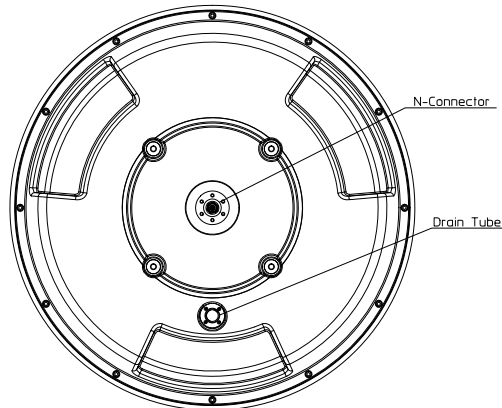

Make sure the draining gasket or drain tube is not blocked. If the antenna is mounted on a pole, make sure the pole is hollow inside and open at the bottom, allowing water from the gasket to escape and providing ventilation for the antenna.

If the antenna TT-3052A/B is mounted on a flat surface, use 10 mm spacers (washers) at each bolt so that the gasket in the center of the antenna bottom is free and water can escape. For the antenna TT-3052C make sure there is free space between the drain tube and the mounting surface so water can escape.

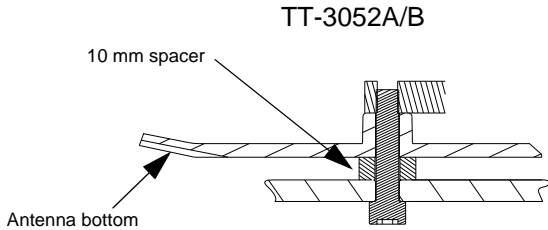

Vibration, SAILOR 500 FleetBroadband antenna

Install the antenna where vibrations are limited to a minimum. Always use all 4 screws when installing. It is recommended to use screws of A4 quality / stainless steel.

2.3.4 Mounting the antenna

Overview

The radome can now be installed on the ship with 4 stainless steel bolts fastened to the hull or to a mast.

For information on mast mounting, see *Antenna mast design* on page 15.

Mounting the SAILOR 500 FleetBroadband antenna on the hull

Make sure the antenna has line of sight to the satellites. When the antenna is mounted directly on the hull, it may be difficult to obtain line of sight, especially down to -25° , which is the maximum rotation angle (pitch and roll) for the SAILOR 500 FleetBroadband antenna.

Use M10 bolts for mounting the SAILOR 500 FleetBroadband antenna.

For TT-3052A/B: The bolt thread must not penetrate more than 12 mm (or 8 turns of the bolt) - and not less than 6 mm (or 4 turns of the bolt)- into the threaded part of the bushings in the antenna. Fasten the bolts with 25 ± 5 Nm torque.

For TT-3052C: The bolt thread must not penetrate more than 25 mm (or 16 turns of the bolt) - and not less than 10 mm (or 6 turns of the bolt)- into the threaded part of the bushings in the antenna. Fasten the bolts with 30 ± 5 Nm torque.

The only electrical connector is a single N-connector in the center bottom of the radome.

Important

For TT-3052A/B: The drainage holes at the bottom of the antenna must have a clearance of 10 mm above the base plane. Use spacers to “lift” the antenna. If the base plane is curved, it may be necessary to place extra spacers to ensure the clearance of 10 mm.

For TT-3052C: Make sure there is free space between the drain tube and the mounting surface so water can escape

Mounting the SAILOR 250 FleetBroadband antenna on the hull

Make sure the antenna has line of sight to the satellites. When the antenna is mounted directly on the hull, it may be difficult to obtain line of sight, especially down to -60° , which is the maximum rotation angle (pitch and roll) for the SAILOR 250 FleetBroadband antenna.

Use M6 bolts for mounting the SAILOR 250 FleetBroadband antenna.

The bolt thread must not penetrate more than 12 mm (or 8 turns of the bolt) - and not less than 6 mm (or 4 turns of the bolt)- into the threaded part of the bushings in the radome. Fasten the bolts with 7-8 Nm torque.

The only electrical connector is a single TNC-connector in the bottom of the radome.

2.4 Placing the terminal

2.4.1 Overview

Because the terminal comes in two versions, the following description contains

- one section for the SAILOR FleetBroadband terminal and
- one section for the SAILOR FleetBroadband 19" Rack Terminal

2.4.2 Where to place the SAILOR FleetBroadband terminal

Temperature conditions

The terminal must be placed in a ventilated area with free space around all sides of the unit, except the bottom side.

Ambient temperature range is -25°C to $+55^{\circ}\text{C}$.

If the terminal is installed in a location where the ambient temperature may exceed 45°C , we recommend placing the terminal where unintentional contact is avoided. If the maximum ambient temperature does not exceed 45°C , the terminal can be placed in a public area.

Grounding access

The terminal is designed with a case for bulkhead or desktop installation.

The case is equipped with mounting brackets, making it possible to secure the unit on a bulkhead.

See *Outline dimensions, SAILOR FleetBroadband terminal* on page 143 in Appendix B.

Important

The terminal must be placed in an area where access to the hull or equivalent grounding can be reached within 0.5 m.



2.4.3 Where to place the SAILOR FleetBroadband 19" Rack Terminal

Temperature conditions

Ambient temperature range is -25°C to $+55^{\circ}\text{C}$.

Note

If you install other equipment close to the terminal in the rack, first make sure the equipment can withstand the heat that may be dissipated from the SAILOR FleetBroadband 19" Rack Terminal. In max. ambient temperature the surface of the terminal may reach a temperature close to 70°C .

Grounding access

The terminal is designed for installation in a 19" rack. We recommend grounding the terminal through the rack.

See *Outline dimensions, 19" Rack Terminal* on page 146 in Appendix B.

Important

The rack for the terminal must be placed in an area where access to the hull or equivalent grounding can be reached within 0.5 m.



2.5 Installing the SAILOR FleetBroadband terminal

2.5.1 Overview

Because the terminal comes in two versions, there are two sections describing installation of the terminal:

- one section for the SAILOR FleetBroadband terminal (this section) and
- one section for the SAILOR FleetBroadband 19" Rack Terminal (*Installing the terminal* on page 46).

2.5.2 Grounding the terminal

Antenna cable

The antenna is connected to the terminal by means of a coax cable.

For the SAILOR 500 FleetBroadband antenna the coax cable is connected with a TNC connector at the terminal end and an N connector at the antenna end.

For the SAILOR 250 FleetBroadband antenna the coax cable is connected with a TNC connector at both ends.

For information on antenna grounding, see *Antenna grounding* on page 23.

At the terminal end, it is strongly recommended to ground the antenna cable.

- If you are using the Extended cable support for the terminal the TNC connector is grounded through the cable support, which must be connected to the hull or other common ground. For further information on the Extended cable support, see *Mounting the Extended cable support* on page 45.
- If you are not using the Extended cable support, it is still strongly recommended to connect the antenna cable to common ground at the terminal end. Use a short coax cable from the terminal to the grounding point, where the short cable is connected to the antenna cable.

Ground stud

To ensure that the terminal is grounded – also if the cable is disconnected from the terminal, connect an extra ground wire to the ground stud on the terminal. This ground wire must be a heavy wire or braid cable with a larger diameter than the coax cable. The ground stud is located next to the power switch.



Extending the ground plane

In some cases it may not be possible to access the hull and at the same time place the terminal in a suitable place.

A way to insure good grounding and at the same time make it possible to ground the coax cable - is to extend the ship ground plane by means of copper foil. The maximum length of the foil is determined by the width of the foil.

Copper foil 5 cm wide: Max 50 cm

Copper foil 10 cm wide: Max 100 cm

Copper foil 20 cm wide: Max 200 cm

Note | The foil must be at least 0.1 mm thick.

Connect the foil to the hull by plenty of screws or hard-soldering. Run the foil past the place where the short antenna cable is to be grounded and mount a

grounding kit on top of the foil. A suitable grounding kit is available from Thrane & Thrane.

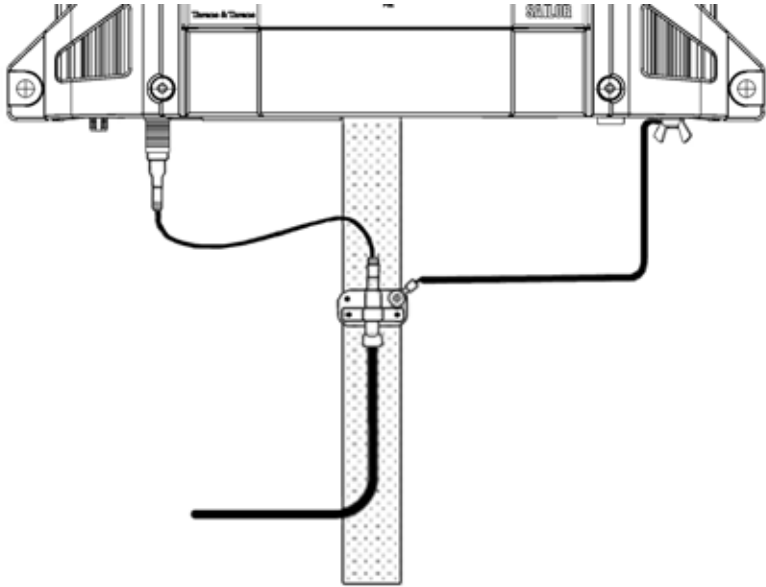

For further grounding information read Appendix C *Grounding and RF protection* on page 149.

2.5.3 Cable support systems

Thrane & Thrane A/S offers two cable support systems.

- The **Basic cable support** comes with the terminal as part of the delivery. It is a simple system to which you can secure your cables using cable strips. For information on how to mount the Basic cable support, see the next section *Mounting the Strain Relief Bracket*.
- The **Extended Cable support** is longer than the Basic cable support, and has connectors for the cables, providing a better ground connection. For information on how to mount the Extended cable support, see *Mounting the Extended cable support* on page 45.

2.5.4 Mounting the Basic cable support

The Basic cable support comes with the terminal as part of the delivery.

When mounted on the terminal the Basic cable support offers a number of holders to which you can secure the cables from the terminal, using cable strips.

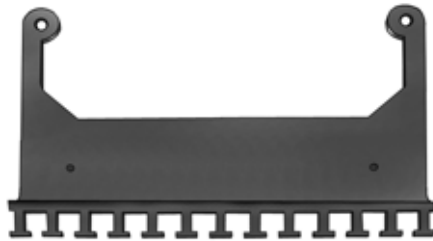

To mount the Basic cable support, do as follows:

1. Remove the two rubber washers from the bottom of the terminal at the connector panel end. The threaded bushings underneath the rubber washers are used for mounting the cable support.

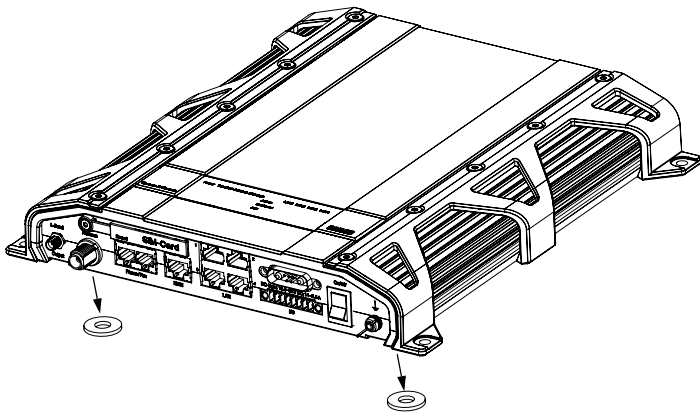

2. Fasten the Basic cable support to the terminal using two M4 x 6 mm countersunk screws.

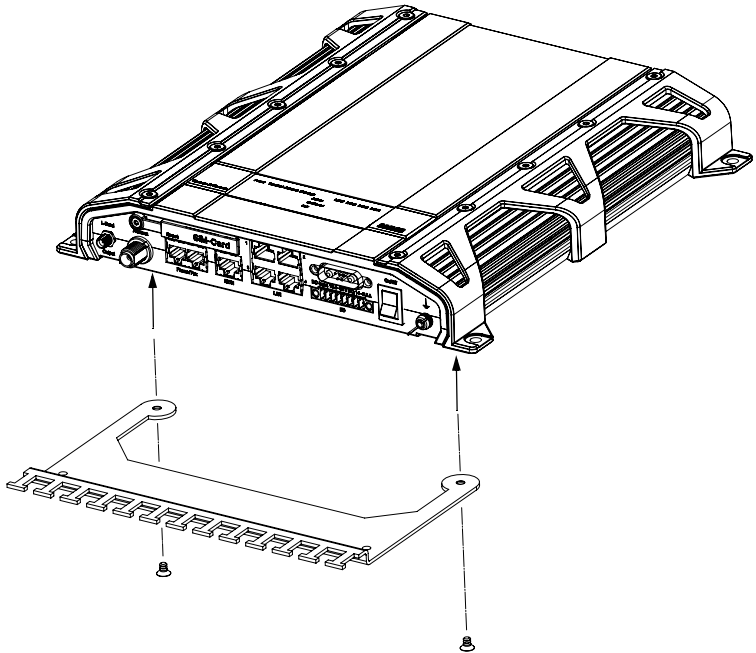

3. Install the terminal as described in *Installing the terminal on a bulkhead* on page 39 or *Installing the terminal on a desktop* on page 41.

2.5.5 Mounting the Extended cable support

The Extended cable support is available from Thrane & Thrane A/S.

The Extended cable support offers connectors and grounding for the antenna cable, as well as a number of holders to which you can secure the cables from the terminal, using cable strips.



To mount the Extended cable support, do as follows:

1. Fasten the cable support to the terminal from the bottom, using the screws in the Extended cable support kit.
2. Install the terminal with the cable support as described in the following sections.

2.5.6 Installing the terminal on a bulkhead

Terminal with no cable support

Do as follows to mount the terminal on a bulkhead:

1. Insert four screws through the mounting holes and into the mounting surface. If the mounting surface is used for grounding, make sure that you have a good electrical connection to the surface.



2. Connect all cables.
Make sure that the grounding requirements are met. See *Grounding and RF protection* on page 149.

Terminal with Basic cable support

First mount the Basic cable support on the terminal as described in *Mounting the Basic cable support* on page 36.

1. Mount the terminal with the Basic cable support on the bulkhead by inserting four screws through the holes in the mounting bracket and into the mounting surface.
2. Connect all cables.
Make sure that the grounding requirements are met. See *Grounding and RF protection* on page 149.
3. Secure the cables to the cable support using cable strips.

Terminal with Extended cable support

First mount the Extended cable support on the terminal as described in *Mounting the Extended cable support* on page 38.

1. Mount the Extended cable support with the terminal on the bulkhead by inserting six screws through the holes in the Extended cable support and into the mounting surface.
2. Connect the short cables between the terminal and the cable support.
3. Connect all other cables.
Make sure that the grounding requirements are met. See *Grounding and RF protection* on page 149.
4. Secure the cables to the cable support using cable strips.

2.5.7 Installing the terminal on a desktop

Four rubber feet make the terminal well suited for desktop installation. Simply place the terminal on a desktop and connect all cables. Make sure the grounding requirements are met. See *Grounding and RF protection* on page 149.

If required, fasten the terminal to the desktop with four screws, as described in the previous section *Installing the terminal on a bulkhead*.

2.6 Installing the 19” Rack Terminal

2.6.1 Overview

Because the terminal comes in two versions, there are two sections describing installation of the terminal:

- one section for the SAILOR FleetBroadband terminal (the previous section) and
- one section for the SAILOR FleetBroadband 19” Rack Terminal (this section)

2.6.2 Grounding the terminal

Antenna cable

The antenna is connected to the terminal by means of a coax cable.

For the SAILOR 500 FleetBroadband antenna the coax cable is connected with a TNC connector at the terminal end and an N connector at the antenna end.

For the SAILOR 250 FleetBroadband antenna the coax cable is connected with a TNC connector at both ends.

For information on antenna grounding, see *Antenna grounding* on page 23.

At the terminal end, it is strongly recommended to ground the antenna cable.

Use a short cable from the terminal to a grounding point in the rack and connect the short cable to the antenna cable at this grounding point, making sure the shield of the connector is properly connected to the rack.

Ground stud

To ensure that the terminal is grounded – also if the cable is disconnected from the terminal, connect an extra ground wire from the rack to the ground stud on the terminal. This ground wire must be a heavy wire or braid cable with a larger diameter than the coax cable. The ground stud is located next to the power switch.



2.6.3 Mounting the Strain Relief Bracket

The Strain Relief Bracket comes with the terminal as part of the delivery.

When mounted on the terminal the Strain Relief Bracket offers a number of holders to which you can secure the cables from the terminal, using cable strips.

To mount the Strain Relief Bracket, do as follows:

1. Unscrew the two screws in the connector panel.



2. Fasten the Strain Relief Bracket to the terminal with the screws from step 1



3. Install the terminal as described in *Installing the terminal* on page 46.

2.6.4 Mounting the Extended cable support

The Extended cable support is available from Thrane & Thrane A/S.

The Extended cable support offers connectors and grounding for the antenna cable, as well as a number of holders to which you can secure the cables from the terminal, using cable strips.

To mount the Extended cable support, do as follows:

1. Fasten the cable support to the terminal from the bottom, using the screws in the Extended cable support kit.
2. Install the terminal with the cable support as described in the following sections.



2.6.5 Installing the terminal

To install the terminal, do as follows:

1. Slide the terminal into a 1U space in a 19" rack.
2. Mount two screws in each side through the holes in the front and fasten the screws to the rack.
3. Connect all cables.

Note

In order to make the power switch on the front of the terminal functional, remember to connect the green and orange wires from the DC cable to the terminal block as described in the next chapter, *Connecting power*.

Make sure that the grounding requirements are met. See *Grounding and RF protection* on page 149.

Connecting power

3.1 Power source

There are different options for the power supply:

- The 24 V DC ship supply provides power for the terminal.
- A 12 V DC supply provides power for the terminal. Note that the maximum allowed source impedance is much lower for a 12 V DC supply than for a 24 V DC supply. Also, the total output power available for Power over Ethernet is limited when the power supply is 12 V DC.
- A 230 V AC supply provides power through an AC/DC power supply.

Be aware of high start-up peak current: 20 A at 24 V, 5 ms.

The terminal is equipped with an internal 20 A Fuse, so no external fuse is necessary in order to protect the terminal. However, in order to avoid short circuit in the power cable/connector, the ship's DC outlet should be protected by a 30 A fuse or circuit breaker.

3.2 Power cable selection

3.2.1 Source impedance

The length of the power cable depends on the type of cable used and the source impedance of the DC power installation in the ship.

The maximum allowed source impedance depends on the usage of the power range of the terminal DC input (10.5 - 32 V DC; 14 A - 5.5 A).

Select a power outlet from the DC system and measure the source impedance of the ship installation as described in the next section.

Note

If the total impedance is higher than the limits stated in this section, the terminal may become unstable and start to on/off oscillate.

The total impedance is made up of the source impedance of the ship power supply plus the impedance of connected cables including connectors and joints where cables are extended.

For further recommendations on power cable selection, see *Power cable recommendations* on page 50.

3.2.2 Measuring the ship source impedance

Select a power outlet from the ship 24 V DC or 12 V DC system, and measure the source impedance of the ship installation as described below.

1. Measure the voltage without load (R.var disconnected).
2. Set the current to e.g. 1 A by adjusting R.var.
3. Measure the corresponding voltage change.

Example: 1 A and 50 mV. Source impedance: $50 \text{ mV}/1 \text{ Amp} = 50 \text{ m}\Omega$.

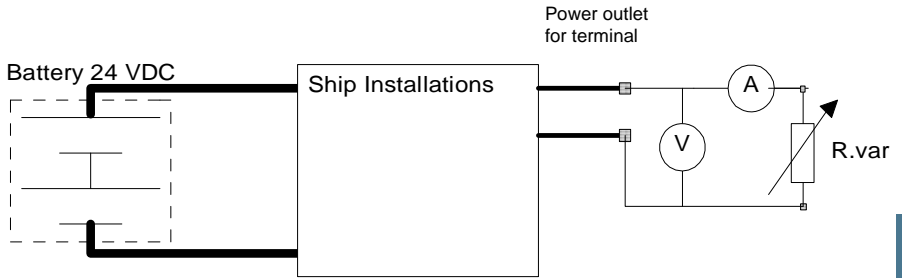

3.2.3 Power cable recommendations

Overview

The terminal is delivered with a power cable, which can be extended according to the recommendations in this section.

- When extending the power cable, positive and negative supply wires must be installed closely together side by side to keep cable inductance low.
- Ensure that cable inductance for the selected cable at the desired length is below the 50 μH requirement.

The power cable contains the following wires:

Color of wire in power cable	Pin number in connector	Function
Red	A1	Vin+
Black	A2	Vin-
Black	1	not connected
Green	2	Remote on/off
Brown	3	not connected
Red	4	not connected
Orange	5	Remote on/off

The power cable for the SAILOR FleetBroadband 19" Rack Terminal is split in two, so that the Remote on/off wires are ready to connect to the front power switch.

For information on how to connect to the front power switch, see *19" rack version only: Connecting to the power switch on the front* on page 55.



The remote on/off wires can be used to connect to:

- The front power switch on the 19" rack version of the terminal, **or**
- a remote switch

Note

It doesn't matter which remote on/off wire connects to which terminal on the remote switch or the front power switch.

For information on how to connect to a remote switch, see *Connecting a Remote on/off switch* on page 57.

Calculating the maximum power cable extension

For 24 V DC operation, the total impedance must be max. 500 m Ω , including the source impedance in the ship installation.

For 12 V DC operation, the total impedance must be max. 85 m Ω , including the source impedance in the ship installation.

The total impedance is made up of the following:

- the source impedance in the ship installation
- the cable impedance of the supplied power cable, including the impedance in the joint of the two cables. In the following example, the impedance of the cable and joint is set to 10 m Ω (1 m power cable). Note that if the cable length or type is changed, the impedance will change accordingly.
- the extension cable impedance.

To calculate the maximum cable extension, do as follows:

1. First measure the source impedance in the ship installation as shown in *Measuring the ship source impedance* on page 48.
2. Then find the resistance per meter for the cable type you are going to use.
For 4 mm²/AWG 11, the value is 4 m Ω /m at 20°C
For 1.5 mm²/AWG 15, the value is 10 m Ω /m at 20°C
For other cable types, refer to the data sheet for the cable.
3. Calculate the maximum allowed impedance in the extension cable as follows:
Max. allowed impedance in extension cable = max. total impedance - (measured source impedance + impedance of the supplied cable).
4. Then calculate the max. extension cable length as follows:
Max. length = 0.5 x $\frac{\text{Max. impedance in extension cable (from step 3)}}{\text{impedance/meter (from step 2)}}$

The length is multiplied by 0.5 above because there are two conductors in the cable.

Example:

Ship supply voltage: 12 V DC

Ship source impedance (measured): 50 mΩ

Extension cable type: 4 mm² (AWG 11)

$$\text{Max. cable extension} = 0,5 \times \frac{85\text{m}\Omega - (50\text{m}\Omega + 10\text{m}\Omega)}{4\text{m}\Omega/\text{m}} = 3,12\text{m}$$

In this case, the power cable can be extended with up to 3.12 m.

If you need a longer cable, you can double the maximum allowed length by connecting two cables instead of one, or you can use a cable with a larger diameter.

3.3 Connecting power

3.3.1 Connecting the power cable

To connect the power cable

Do as follows to connect the power cable:

1. Connect the red (+) and black (-) wires of the power cable to the ship's 24 V DC supply according to the recommendations in the previous sections.
2. Connect the D-sub connector on the power cable to the DC input connector on the terminal.



If you need a **remote on/off** function, you may use one of the following options:

- Connect the Remote on/off wires in the power cable to a remote switch. **Note that this is not possible if you are using the front switch on a SAILOR FleetBroadband 19" Rack Terminal!** For further information, see *Connecting a Remote on/off switch* on page 57.
- Connect the ignition pins in the I/O connector to the ignition of your vessel. For further information, see *Connecting to the ignition* on page 56.

For information on pin-out, see *DC power input* on page 61.

For specifications of the DC input on the terminal, see *SAILOR FleetBroadband terminal* on page 139.

19" rack version only: Connecting to the power switch on the front

The SAILOR FleetBroadband 19" Rack Terminal has a power switch on the front in addition to the switch in the connector panel.



The power cable included in the delivery is prepared for connection to the front switch. It has two separate wires (one green, one orange), which can be connected to the terminal block.



If you want to use the power switch on the front of the terminal to switch the terminal on and off, connect the remote on/off pins in the DC connector to the terminal block in the connector panel as follows:

1. Press with a small screwdriver at one of the two terminals in the terminal block to open the terminal. Then insert the end of the green wire into the terminal and remove the screwdriver.

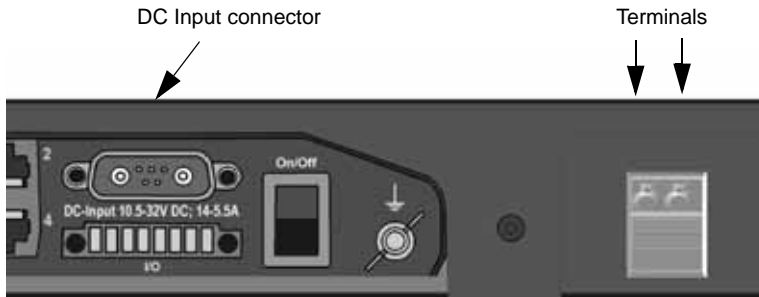

2. Press with a screwdriver on the other terminal in the terminal block and insert the end of the orange wire into the terminal.

Note

It doesn't matter which remote on/off wire connects to which terminal in the terminal block.

3.3.2 Connecting to the ignition

The terminal has an ignition function. When this function is used, the terminal switches on/off when you start/stop the engine of your vessel (provided the power switch on the terminal is on; on the 19" rack version both power switches must be on).

Note

You must set up the ignition function in the terminal. For details, see the user manual for your SAILOR FleetBroadband system.

To implement the ignition function, connect the appropriate pin in the I/O connector to the ignition key switch:

- Active high (default): Connect pin 5 to Ground. Connect pin 8 to “high” (10.5-32 V DC) when the ignition is on.
- Active low: Connect pin 8 to positive DC voltage (10.5-32 V DC). Connect pin 5 to Ground (< 1.2 V DC) when the ignition is on.

For pin-out and default functions, see *Discrete I/O interface* on page 71.

For information on the standby current when the ignition power is off, see *Standby current* on page 141 in the general specifications.

3.3.3 Connecting a Remote on/off switch

The terminal has a remote on/off function. When the terminal power switch is in the “on” position you can remote-control the power function.

Note

The remote on/off function is not available if you have connected the front power switch on a SAILOR FleetBroadband 19” Rack Terminal.

By installing a switch that can short-circuit the “Remote on/off” pins (2 and 5) in the power connector you can power the terminal on or off with this remote switch.

When pins 2 and 5 are not short-circuited and valid input power is present, the terminal is powered on, provided the Power switch is in the “on” position.

For pin-out for the power connector and a description of the wire colors in the power cable, see *Pin-out* on page 62.

For information on the standby current when the remote on/off switch is off, refer to *Standby current* on page 141 in the *General specifications (including 19” rack version)*.

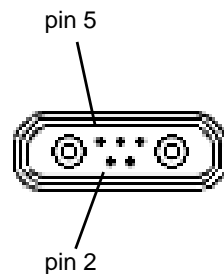

Hardware interfaces

4.1 The connector panel

The connector panel is placed at one end of the terminal and has the following connectors:



- 1 L-Band connector for automatic delivery of maritime broadcast data
- 1 Antenna connector (TNC)
- 2 Phone/Fax connectors (Port 1 is closest to the antenna connector)
- 1 ISDN connector
- 4 LAN connectors with Power over Ethernet (PoE)
- 1 DC power input connector for connection to 10.5-32 V DC, with optional remote on/off
- 1 Input/Output connector with 5 inputs/outputs for external control or signaling
- 1 ground stud with wing nut
- 19" rack version only: 1 terminal block with 2 terminals for connection to front power switch

For information on how to connect to a specific interface, see the next sections.

4.2 Antenna interface on terminal

4.2.1 Overview

The antenna interface on the terminal connects to the TT-3052A/B antenna in the SAILOR 500 FleetBroadband system or to the TT-3050A antenna in the SAILOR 250 FleetBroadband system.

The antenna connector on the terminal is a TNC female connector placed in the connector panel.

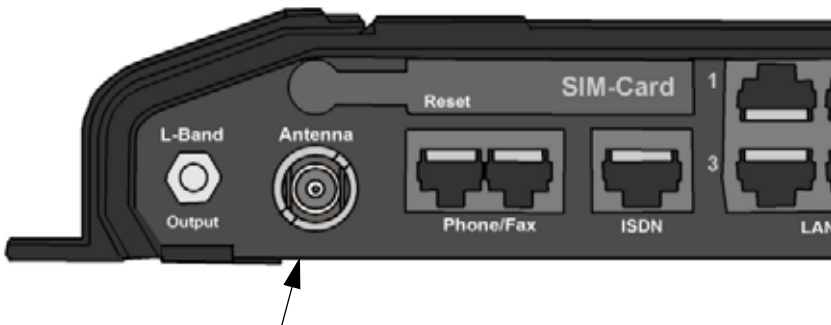

For information on cables and how to install and connect the antenna, see *Installing the antenna* on page 23.

4.2.2 Pin-out

The below drawing shows the TNC female connector in the terminal.

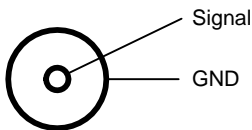

4.3 DC power input

4.3.1 Overview

The DC power input for the terminal is a 10.5 - 32 V DC; 14 A - 5.5 A input with a remote on/off function. The input is protected against reverse polarity.

The power connector is a D-sub connector placed in the connector panel.

Important

On the SAILOR FleetBroadband 19" Rack Terminal, do **not** connect power to the terminal block in the right side of the connector panel! The terminal block is only for connection of the remote on/off signal.

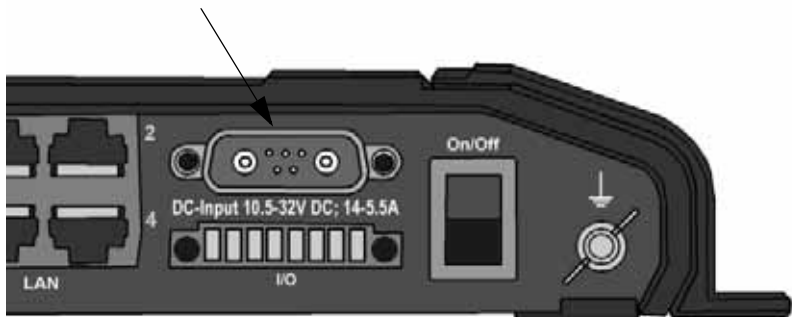

For information on power recommendations and how to connect, see *Connecting power* on page 47.

For SAILOR FleetBroadband 19" Rack Terminal: To be able to use the power switch on the front panel of the terminal you must connect the remote on/off pins in the DC connector to the terminal block in the right side of the connector panel. For further information, see *19" rack version only: Connecting to the power switch on the front* on page 55.

4.3.2 Pin-out

The power connector is a Mixed D-Sub connector 7W2, control pin male/ power pin male. The below table shows the pin-out for the connector and the colors of the corresponding wires.

Pin number	Pin function	Color of wire in power cable
A1	Vin+	Red
A2	Vin-	Black
1	not connected	(Black)
2	Remote on/off	Green
3	not connected	(Brown)
4	not connected	(Red)
5	Remote on/off	Orange

Mixed D-Sub connector, 7W2, male

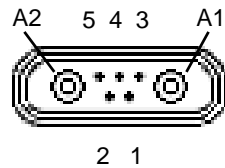

4.4 Ground stud

The terminal has a ground stud with a wing nut. The ground stud is located in the connector panel and is used for grounding the terminal.



For information on how to ensure proper grounding of the terminal, see *Grounding the terminal* on page 33 and *Grounding and RF protection* on page 149.

4.5 19” rack version only: Terminal block

The terminal block in the connector panel is used to connect the remote on/off pins from the DC connector to the power switch in the front of the terminal.

Important

Do **not** connect power to the terminal block!

Connection for power switch on front panel



For information on how to connect, see *19” rack version only: Connecting to the power switch on the front* on page 55.

4.6 Analog Phone/Fax interface

4.6.1 Overview

The terminal has two RJ-11 ports, which can be used for connection of analog phones or fax machines.

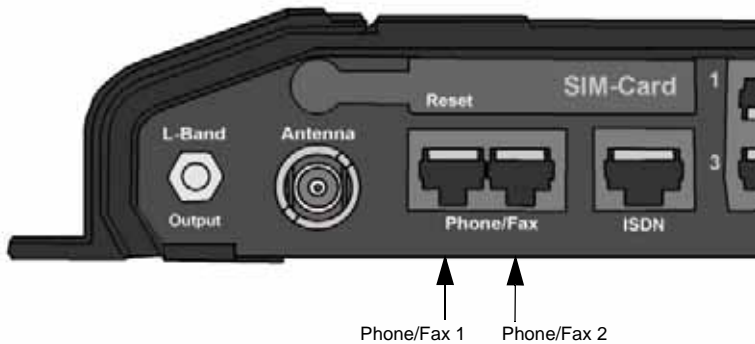

4.6.2 Pin-out

The Phone/Fax connectors are RJ-11, 6/4 female connectors. The table and figure below show the connector outline and pin assignments.

Pin number	Pin function
1	-
2	not connected
3	Tip
4	Ring
5	not connected
6	-

RJ-11 female connector

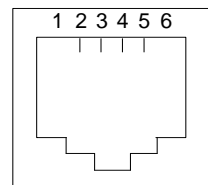

4.7 ISDN interface

4.7.1 Overview

The terminal has one ISDN connector for connecting an ISDN phone or an ISDN modem. The ISDN interface supports 56/64 kbps data rate. It is configured as the network side, i.e. Rx is an input and Tx is an output.



4.7.2 Pin-out

The figure and table below show the connector outline and pin assignments.

Pin number	Pin function
1	not connected
2	not connected
3	Rx+ (c) input
4	Tx+ (d) output
5	Tx- (e) output
6	Rx- (f) input
7	not connected
8	not connected

RJ-45 female connector

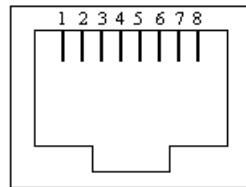

4.8 LAN interface

4.8.1 Overview

The terminal has four Ethernet LAN ports with Power over Ethernet (PoE). The standard for the Ethernet ports is IEEE 802.3af, and the connectors are RJ-45 connectors.



4.8.2 Power over Ethernet (PoE)

One power supply powers all four interfaces with a floating 48 V DC supply (44 - 57 V DC). Therefore, the interfaces are not galvanically separated from each other. All Tx signals are DC connected to the Positive PoE Voltage and all Rx signals to the Negative PoE Voltage.

The total output power from all 4 interfaces is

- 64 W at 24 V DC power supply
- 32 W at 12 V DC power supply.

All interfaces can support devices of power class 1, 2 and 3 (4, 7 and 15.4 Watt), as long as the total power consumption does not exceed the above limits. If the limits are exceeded, the LAN ports are prioritized so that LAN port 1 has the highest priority. For example, if all ports are used and the total power consumption is too high, port 4 is shut down.

In case of power hold-up (failure on input power), PoE will be turned off.

4.8.3 Pin-out

The figure and table below show the connector outline and pin assignments.

Pin number	Pin function
1	TxD+ input (positive PoE)
2	TxD-input (positive PoE)
3	RxD+ output (negative PoE)
4	not connected
5	not connected
6	RxD- output (negative PoE)
7	not connected
8	not connected

RJ-45 female connector

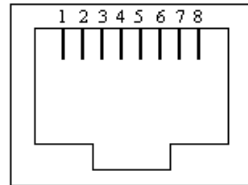

4.8.4 Connecting the Thrane IP handset

To connect the Thrane IP Handset to the terminal, do as follows:

Connect the cable from the IP cradle to one of the LAN connectors on the terminal, preferably port 1. In case of insufficient power to the LAN PoE the LAN ports are prioritized, so that port 1 is the last to be shut down.

Note that the handset and terminal must be set up to be able to communicate with each other. For further information, refer to the user manual for the handset.

The maximum length of the cable between IP cradle and terminal is 80 m.

Note

If you insert a switch or similar between the cradle and the terminal, make sure that it conforms to the industry standard **IEEE 802.3 af (using data pairs)**.

4.9 Discrete I/O interface

4.9.1 Overview

The terminal has an I/O connector with 5 configurable inputs/outputs.



The connector is a WieCon Type 8513S connector. A mating I/O connector is included in the delivery.

4.9.2 Pin-out

The figure and table below show the connector outline and pin assignments.

WieCon Type 8513S connector

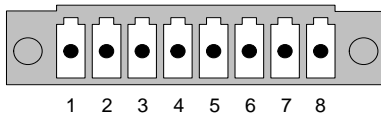

Pin number	Connection	Default configuration ^a
1	GPIO 1	Ringer output
2	GPIO 2	Warning/Error output
3	GPIO 3	Mute output
4	GPIO 4	Radio silence input
5	GPIO 5	Ignition input
6	Chassis GND	Chassis GND
7	DC out	9-15 V DC, 50 mA
8	DC in	(ignition input)

- a. The default functions of the I/O pins are described in the next section.

4.9.3 Default configuration of I/O pins

The built-in web interface of the terminal offers a page for configuring the I/O pins.

The functions of the I/O pins are as follows:

Pin 1: Ringer output.

Pin 1 acts as a built-in switch in the terminal. You can configure Pin 1 to be Normally closed or Normally open.

Note

Do not use the Ringer output if you have enabled Local exchange. For information on Local exchange, refer to the User manual.

- **Normally closed (default):**
The internal switch at pin 1 is normally closed (pin 1 is connected to ground). When the terminal is notified of an incoming call from the satellite interface, the switch opens (no connection to ground). When the call is answered, or the caller gives up and releases the call, the switch is closed again.
- **Normally Open:**
The internal switch at pin 1 is normally open (no connection to ground). When the terminal is notified of an incoming call from the satellite interface, the switch is closed (pin 1 is connected to ground). When the call is answered, or the caller gives up and releases the call, the switch is opened again.

Pin 2: Warning/Error output.

Pin 2 acts as a built-in switch in the terminal. Pin 2 can be used to provide an external signal that indicates active warning/error condition(s). You can configure pin 2 to be Normally closed or Normally open.

- **Normally Closed (default):**
The internal switch at pin 2 is normally closed (pin 2 is connected to ground). When an alarm occurs, the switch opens (no connection to ground). The switch is closed again when all warnings/errors are cleared.
- **Normally Open:**
The internal switch at pin 2 is normally open (no connection to ground). When an alarm occurs, the switch is closed (connected to ground). The switch is opened again when all warnings/errors are cleared.

Pin 3: Mute output.

Pin 3 acts as a built-in switch in the terminal. Pin 3 can be used to provide an external signal that is active during a phone call. The signal can be used to mute external equipment. You can configure pin 3 to Normally closed or Normally open.

- Normally Closed (default):
The internal switch at pin 3 is normally closed (pin 3 is connected to ground). During phone calls, the switch opens (no connection to ground). When the call is ended, the switch is closed again (connected to ground).
- Normally Open:
The internal switch at pin 3 is normally open (no connection to ground). The switch is closed (connected to ground) during phone calls. When the call is ended, the switch opens again (no connection to ground).

Pin 4: Radio silence input.

Activation of this pin causes the system to assume radio silence, i.e. to stop all transmission from the system. The terminal gracefully closes all open connections, and deregisters from the BGAN network. No transmission is allowed until the pin is deactivated. You can configure pin 4 to Active low or Active high.

- Active low (default): Connect pin 4 to ground (< 1.2 V DC) when it should be activated.
- Active high: Connect pin 4 to ground (< 1.2 V DC). When it should be activated, disconnect it from ground.

Pin 5/8: Ignition input.

The ignition function can be used to turn on/off the terminal by means of an external signal. The external signal that triggers the ignition function can be either positive DC voltage or ground. The ignition function uses pin 5 together with pin 8 (DC in). Connect the appropriate pin to the ignition switch as follows:

- Active high (default): Connect pin 5 permanently to Ground. Connect pin 8 to positive DC voltage (10.5-32 V DC) when the ignition is on. To switch off, disconnect pin 8 from the positive DC voltage.

- Active low: Connect pin 8 permanently to positive DC voltage (10.5-32 V DC). Connect pin 5 to Ground (< 1.2 V DC) when the ignition is on. To switch off, disconnect pin 5 from ground.

Note

The Ignition function is normally not used in maritime installations. You may use the Remote on/off function in the power connector instead.

Pin 6: Ground.

(Non-configurable) Pin 6 can be used as an external connection to ground. Pin 6 is connected to Ground inside the terminal.

Pin 7: DC output.

(Non-configurable) Pin 7 can be used as a DC output. The voltage on pin 7 is 9-15 V and the output can supply up to 50 mA. Pin 7 can be used as power supply to a relay, ringer or similar.

For information on how to configure the I/O pins, see the user manual for the SAILOR 500 FleetBroadband and SAILOR 250 FleetBroadband systems.

4.10 L-Band interface

4.10.1 Overview

The terminal has an L-Band output for automatic delivery of maritime broadcast data. Use a coax cable with an SMA connector to connect a broadcast receiver for maritime data to the L-band output.



4.10.2 Pin-out

The figure below shows the pin-out for the SMA female connector.

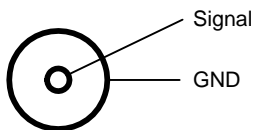

Starting up the system

5.1 Using the SIM card

5.1.1 Inserting the SIM card

The SIM card is provided by your Airtime Provider. Insert the SIM card as follows:

1. Open the SIM cover in the left side of the connector panel.
2. Insert the SIM card into the SIM slot.
Place the card with the chip side facing up as shown.
3. Press gently until it clicks.
4. Slide the lock in front of the SIM card.
5. Close the cover for the SIM slot.



5.1.2 Removing the SIM card

Note

When the SIM card is removed, you cannot use the BGAN menu of the IP handset nor make calls or start data sessions. Only emergency calls are allowed, and only if permitted by the network.

However, if you have an administrator user name and password, you can upload software using the web interface without having a SIM card. For further information, see the user manual for the SAILOR FleetBroadband system.

Remove the SIM card as follows:

1. Open the SIM cover in the left side of the connector panel.



2. Slide the lock aside.

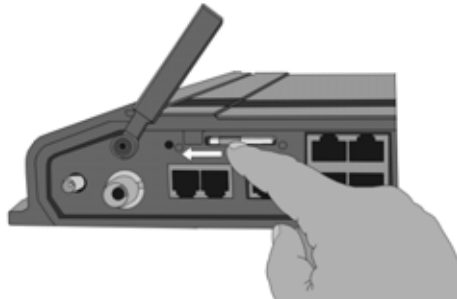

3. Gently push the SIM card and let it pop out.
4. Remove the SIM card and close the cover for the SIM slot.

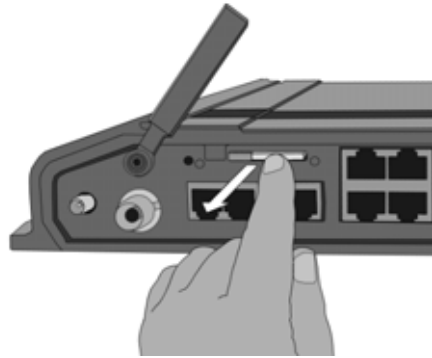

5.2 Powering the system

5.2.1 Switching the terminal on

Using the power switch

Note

If you have the 19" rack version of the SAILOR FleetBroadband terminal, you can use the on/off switch in the front panel. See the next section *19" rack terminal: Using the front power switch*.

To switch on the terminal, use the On/Off switch in the connector panel. It normally takes one or two seconds for the terminal to switch on.



19" rack terminal: Using the front power switch

If you have the 19" rack version of the SAILOR FleetBroadband terminal, flip the switch in the front panel to "1" to switch on the terminal.

It normally takes one or two seconds for the terminal to switch on.



Note

To be able to use the power switch on the front panel, you must leave the On/Off switch in the connector panel in the On position.



Must be On when front panel switch is used



Caution! When the system is powered on, stay clear of the antenna! The antenna emits radio frequency energy, **not only** when the system is used. Always keep a minimum distance of 1.3 m from the SAILOR 500 FleetBroadband antenna and 0.6 m from the SAILOR 250 FleetBroadband antenna.

Using the ignition system

Normally the ignition function is not used in maritime installations. Instead you may want to use the remote on/off function described in the next section.

If you have connected the ignition system of your vessel to the I/O connector, you may leave the power switch in the “on” position and the terminal will switch on/off when you start/stop the engine of your vessel.

Note | If you have the 19” rack version of the terminal, you must leave both power switches in the “on” position to make use of the ignition function.

When the engine is stopped the terminal is in standby mode, meaning that only the primary parts of the system are kept alive. The standby current is max. 15 mA when the ignition is off. For information on how to connect to the ignition, refer to *Connecting to the ignition* on page 56.

You must set up the ignition function in the web interface. For further information, see the user manual for the SAILOR FleetBroadband system.

Note | In some cases, the system may reboot after power-on because of the high start-up current.

Using a remote on/off switch

Note | In the 19” rack version of the terminal the remote on/off function is normally not available, because it is used for the front switch.

If an external switch is connected to the remote on/off pins in the DC connector, you may leave the power switch in the connector panel in the “on” position and use the remote switch to turn the terminal on and off. When the remote switch is off, the terminal is off. However, if you leave the power switch on the terminal in the “on” position, you can always switch the terminal back on with the remote switch. The standby current when the remote switch is off is max. 2 mA. For further information on how to connect a remote on/off switch, see *Connecting a Remote on/off switch* on page 57.

5.2.2 Switching the terminal off

To switch off the terminal, change the position of the power switch again.

Note

Wait at least 5 seconds after power off, before trying to power on the system again.

To switch off the 19" rack version of the terminal, set the power switch in the front to 0 and leave the On/Off switch in the connector panel in the On position.

To switch off using the Ignition function, leave the On/Off switch in the connector panel in the On position and turn off the ignition.

5.3 Entering the SIM PIN for the terminal

5.3.1 Overview

If your SIM card requires a PIN, you have to enter a PIN to use the system. You can enter the PIN using a standard or ISDN phone, the IP handset or the web interface.

For information on how to connect the handset or computer you are going to use, refer to the user manual.

5.3.2 Entering the PIN using a phone or IP handset

To enter the PIN

If you have a phone connected to the terminal, you can use it to enter the PIN at start up.

Do as follows:

- **For an analog or ISDN phone:**
Pick up the phone. When the terminal is waiting for a PIN, you will hear 2

beeps - pause - 2 beeps - etc.

Dial <PIN> followed by #.

When you hear a “busy” tone or a dialing tone, the PIN has been accepted and you can hang up or dial a number.

- **For an IP handset:**

Select the **BGAN** menu, select **ENTER PIN** and enter the user name and password for the terminal. Then enter the PIN for the terminal.

Note

The ENTER PIN menu item is only available if your SIM card requires a PIN, and the PIN has not yet been entered and accepted in the terminal.

Wrong PIN

Analog phone or ISDN phone:

If, instead of the busy tone or dialing tone, you continue to hear 2 beeps - pause - 2 beeps - etc., it means the PIN was not accepted. Check that you have the correct PIN and try again.

If a wrong PIN has been entered three times, you will hear 3 beeps - pause - 3 beeps - etc. This means you have to enter the PUK (PIN Unblocking Key) provided with your SIM card.

After entering the PUK, you must enter a new PIN of your own choice (4 to 8 digits long).

Dial the following:

<PUK> * <New PIN> * <New PIN> followed by # or off-hook key.

Example: If the PUK is 87654321 and the new PIN is 1234, dial **87654321 * 1234 * 1234** followed by # or off-hook key.

If you enter 10 wrong PUKs, the SIM card will no longer be functional. Contact your Airtime Provider for a new SIM card.

IP handset:

After having entered the user name and password for the terminal you have 3 attempts to enter the terminal PIN, before you are asked to enter the PUK (Pin Unblocking Key). The PUK is supplied with your terminal SIM card.

Enter the PUK followed by a new PIN of your own choice. The PIN must be from 4 to 8 digits long.

If you enter a wrong PUK 10 times, the SIM card will no longer be functional, and you have to contact your BGAN Airtime Provider for a new SIM card.

5.3.3 Entering the PIN using the web interface

If your SIM card requires a PIN and the PIN has not yet been entered when you start up the web interface, the start-up page will be the PIN page. Enter the PIN and click **OK**.

For further information on the web interface, see the user manual for your SAILOR FleetBroadband.

5.4 Operating the system

5.4.1 General use

The user manual for the SAILOR FleetBroadband systems describes general use of the system and all the functions of the web interface. It also contains a brief description of how to use the Thrane IP Handset with the terminal.

5.4.2 User interfaces

Overview

The main user interfaces for operation of the system are

- the built-in web interface using a computer with an Internet browser
- the Thrane IP Handset

Built-in web interface

The built-in web interface is used for easy configuration and daily use. You access the web interface from a computer connected to the terminal, using an Internet browser. No installation of software is needed.

An Administrator password is required to access advanced configuration of the system. From factory, the Administrator User name is **admin** and the Administrator password is **1234**.

For further information on the web interface, refer to the user manual for the SAILOR FleetBroadband systems.

IP handset

Apart from the standard functions of an IP handset, the Thrane IP Handset contains a display menu for the SAILOR FleetBroadband system. For further information on the Thrane IP Handset, refer to the user manual for the IP handset.

Service and repair

6.1 Introduction

The Thrane & Thrane SAILOR FleetBroadband systems are designed to operate without preventive routine maintenance.

Although the system is designed and built very service friendly, we strongly recommend that any acting service technician is trained specifically on the product. Repair or repair attempts performed by unqualified personnel may limit the warranty. The warranty on the system is defined and outlined by the distributor that supplied the system.

We do not recommend repairing the terminal on board the ship. Replace the defective unit and have it repaired at a qualified workshop on shore.

Some of the modules in the SAILOR 500 FleetBroadband antenna can be replaced. See the next sections for details.

Note

There are three types of SAILOR 500 FleetBroadband antenna, the TT-3052A, TT-3052B and TT-3052C. The procedure for replacing modules is slightly different for the antennas TT-3052A and TT-3052B/C. Make sure you read the right section for your antenna type.

For further information on warranty and service, you may also use the Thrane & Thrane home page at <http://www.thrane.com>.

6.2 Replacing modules in TT-3052A antenna

6.2.1 Overview

Some of the modules in the TT-3052A antenna can be replaced. See the next sections for details.

6.2.2 Modules in the TT-3052A antenna

Remove the top of the radome to access the antenna modules.

The electronic part of the antenna consists of a number of modules. The following modules are available as spare parts:

- HPA Module (High Power Amplifier)
- ATB/LNA Module (Antenna Tracking Board/Low Noise Amplifier)
- GPS module (Global Positioning System)

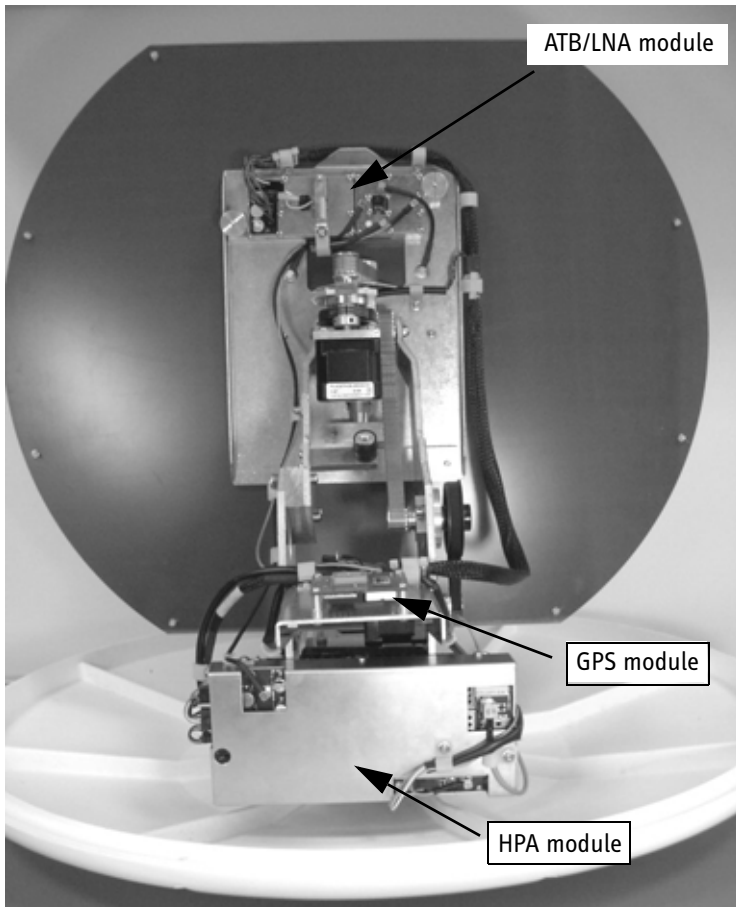

6.2.3 High Power Amplifier (HPA)

Removing the HPA module

To remove the HPA from the antenna, do as follows:

1. Disconnect the six plugs indicated in the drawing below.

Important

Remember the exact position of each plug, so you do not connect to the wrong connector when installing the new module.

Remember to release connector latches on the connectors.

Do **not** pull the wires - pull the plugs.

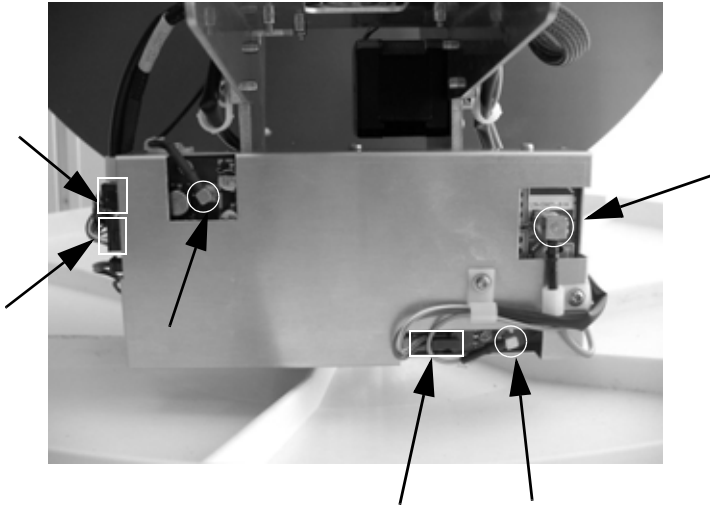

2. Gently lift the cable holders and release the cables.

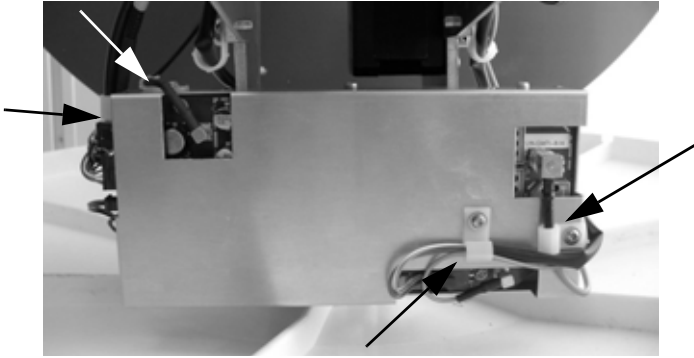

3. Unscrew the four finger nuts on the back of the HPA and gently remove the HPA.

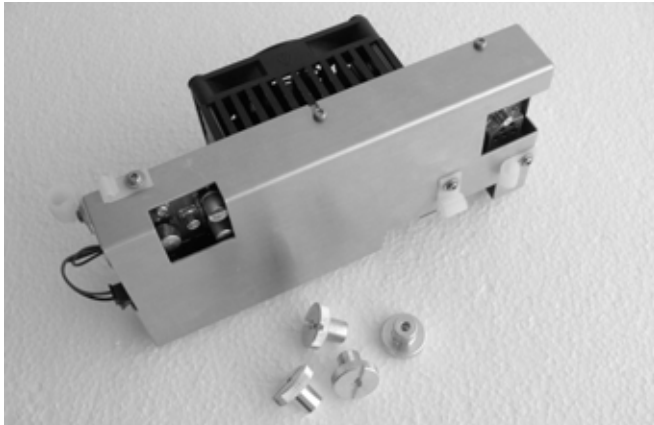
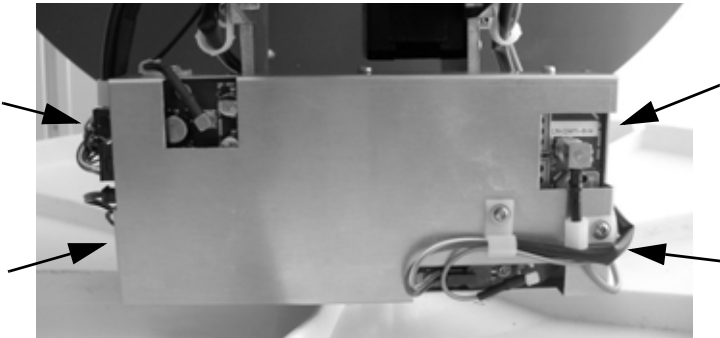

Mounting the HPA module

To mount the new HPA, repeat the above procedure in reverse:

1. Fit the threaded studs on the back of the HPA into the holes in the mounting bracket on the antenna. Apply a small amount of Loctite 243 onto each of the four threaded studs before mounting the finger nuts on the threaded studs. Fasten the nuts with 1.2 Nm torque.
2. Reconnect the plugs. Make sure the plugs are fitted properly. You should hear a click when the plug is fully inserted.
3. Gently lift the cable holders and fit the cables in the holders.

6.2.4 Antenna Tracking Board/Low Noise Amplifier (ATB/LNA)

Removing the ATB/LNA module

To remove the ATB/LNA module from the antenna, do as follows:

1. Disconnect the six plugs indicated in the drawing below.

Important

Remember the exact position of each plug, so you do not connect to the wrong connector when installing the new module.

Remember to release connector latches on the connectors.

Do **not** pull the wires - pull the plugs.

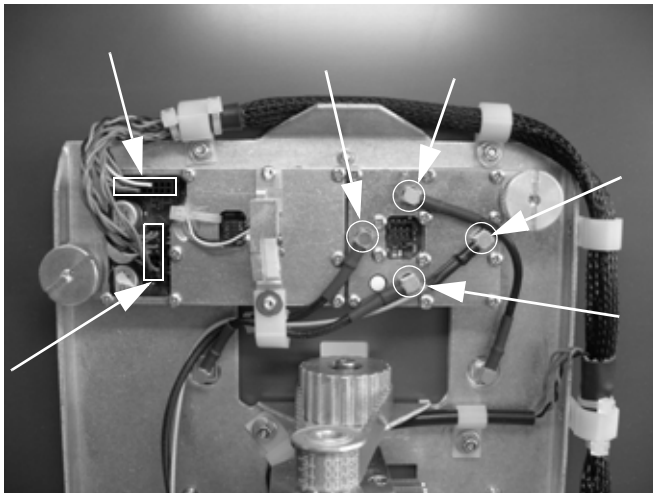

2. Gently lift the cable holder and release the cables.

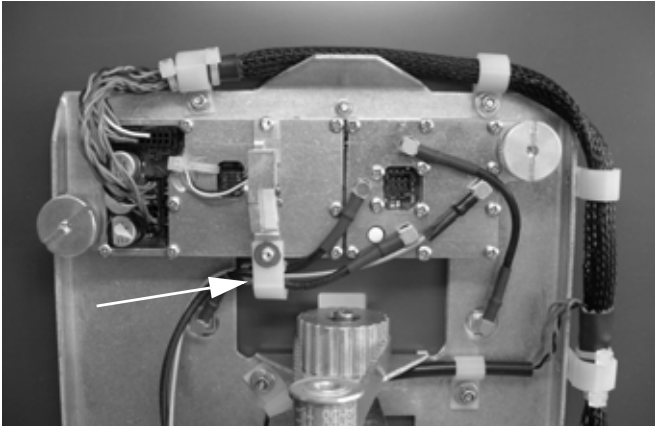

3. Unscrew the two finger nuts and gently remove the ATB/LNA module.

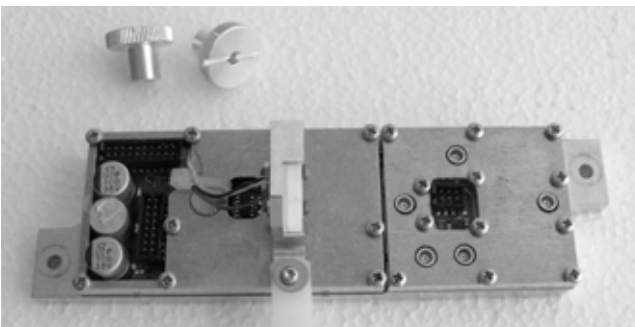
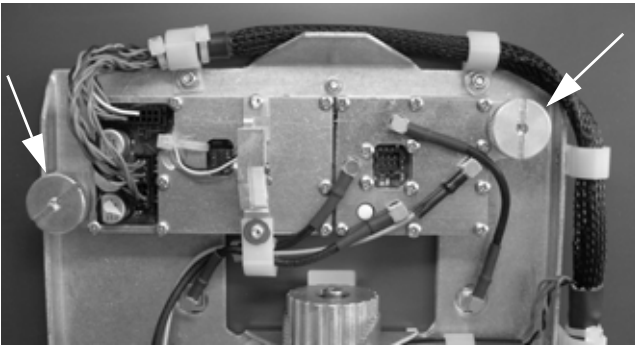

Mounting the ATB/LNA module

To mount the new ATB/LNA module, repeat the above procedure in reverse:

1. Fit the threaded studs on the antenna into the holes in the sides of the ATB/LNA module, and fasten the finger nuts with torque 1.2 Nm.
2. Reconnect the plugs. Make sure the plugs are connected to the right connectors on the antenna, and that they are fitted properly. You should hear a click when the plug is fully inserted.

The cable from the right part of the antenna panel goes to the connector marked A and the cable from the left part of the antenna panel goes to the connector marked B in the below drawing. When those two plugs are inserted, it is easier to see where the remaining plugs belong.

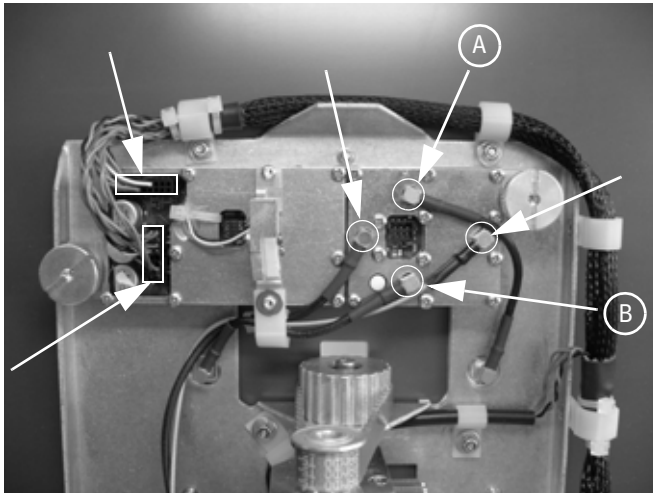

3. Gently lift the cable holder and fit the cables in the holder.

6.2.5 GPS module

Removing the GPS module

To remove the GPS module from the antenna, do as follows:

1. Disconnect the plug from the GPS module.

Important

Remember to release connector latches on the connector.

Do **not** pull the wires - pull the plug.

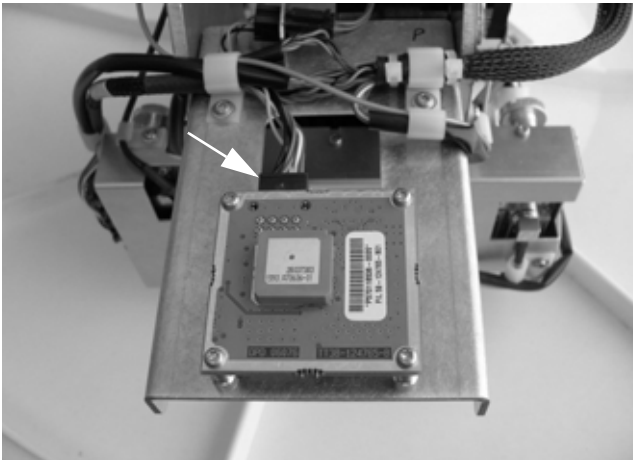

2. Unscrew the four screws on the GPS module with a torx screwdriver and remove the module.

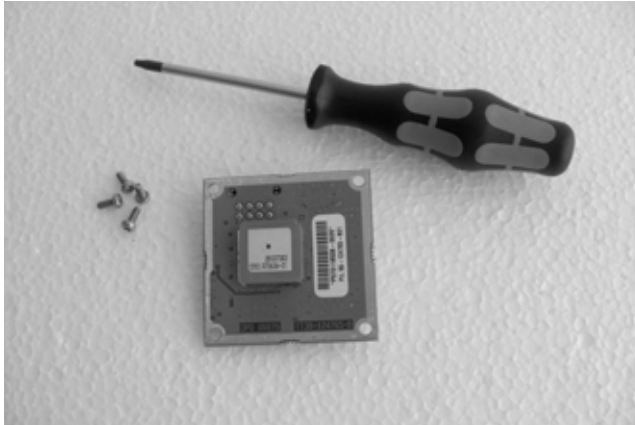

Mounting the GPS module

To mount the new GPS module, repeat the above procedure in reverse:

1. Fit the GPS module over the dedicated four threaded bushings on the mounting plate above the HPA module. See drawing on page page 95.
2. Mount the four screws through the holes in the corners of the GPS module and into the threaded bushings on the antenna. Fasten the screws with torque 1.0 Nm using a torx screwdriver.
3. Reinsert the plug. Make sure the plug is fitted properly.

6.3 Replacing modules in TT-3052B/C antenna

6.3.1 Overview

Some of the modules in the TT-3052B/C antenna can be replaced. See the next sections for details.

6.3.2 Modules in the TT-3052B/C antenna

Remove the top of the radome to access the antenna modules.

The electronic part of the antenna consists of a number of modules. The following modules are available as spare parts:

- HPA (High Power Amplifier)
- ATR (Antenna Tracking Receiver)
- GPS (Global Positioning System)
- ATM (Antenna Tracking Module)

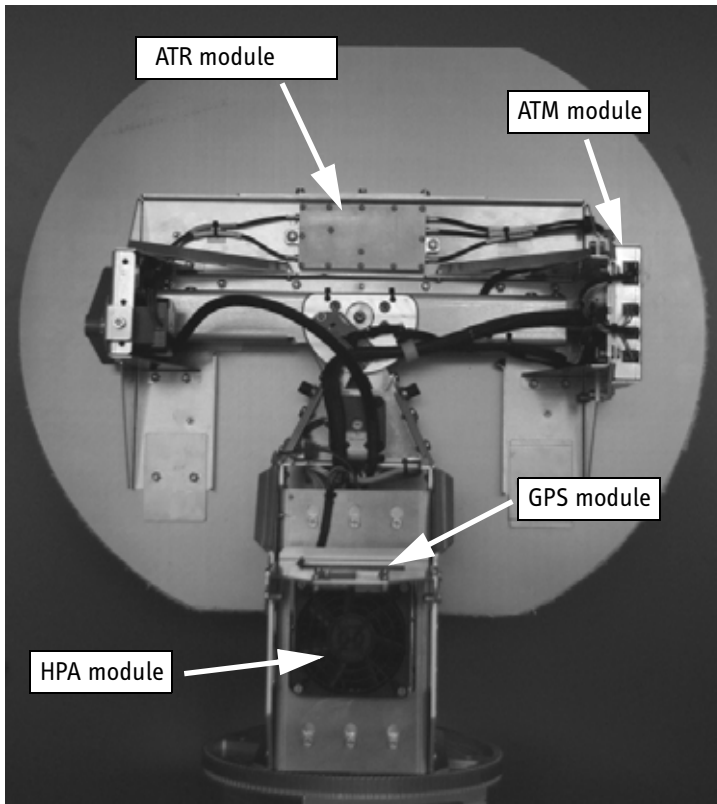

6.3.3 High Power Amplifier (HPA)

Removing the HPA module

To remove the HPA from the antenna, do as follows:

1. Unscrew the four hex screws, two on each side of the pedestal, and remove the shield for the wires.

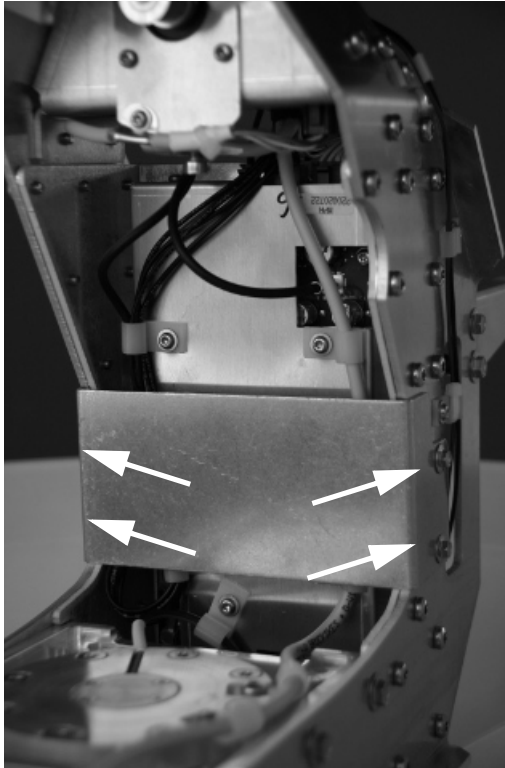

2. Disconnect the seven plugs indicated in the drawing below.

Important

Remember the exact position of each plug, so you do not connect to the wrong connector when installing the new module.

Remember to release connector latches on the connectors.

Do **not** pull the wires - pull the plugs.

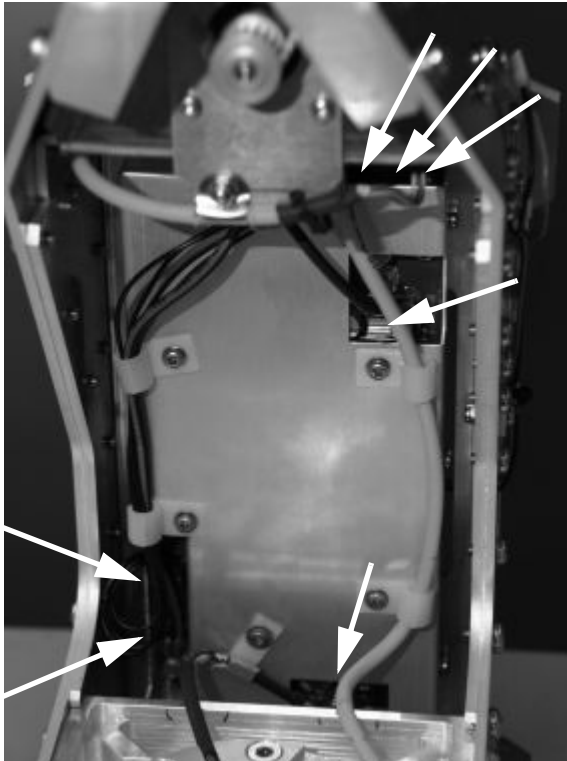

3. Cut the cable ties holding the wires for the fan.
4. Gently lift the cable holders and release the cables.

5. Unscrew the six hex nuts on the back of the HPA and gently remove the HPA.



Mounting the HPA module

To mount the new HPA, repeat the above procedure in reverse:

1. Fit the threaded studs on the back of the HPA into the keyhole shaped holes in the mounting bracket on the antenna. Mount the six hex nuts on the studs and fasten them with 1.2 Nm torque.
2. Reconnect the plugs. Make sure the plugs are fitted properly. You should hear a click when the plug is fully inserted.
3. Gently lift the cable holders and fit the cables in the holders.
4. Fit the shield for the wires and tighten the four hex screws, two on each side of the pedestal.

6.3.4 Antenna Tracking Receiver (ATR)

Removing the ATR module

To remove the ATR module from the antenna, do as follows:

1. Disconnect the five plugs indicated in the drawing below.

Important

Remember the exact position of each plug, so you do not connect to the wrong connector when installing the new module.

Remember to release connector latches on the connectors.

Do **not** pull the wires - pull the plugs.

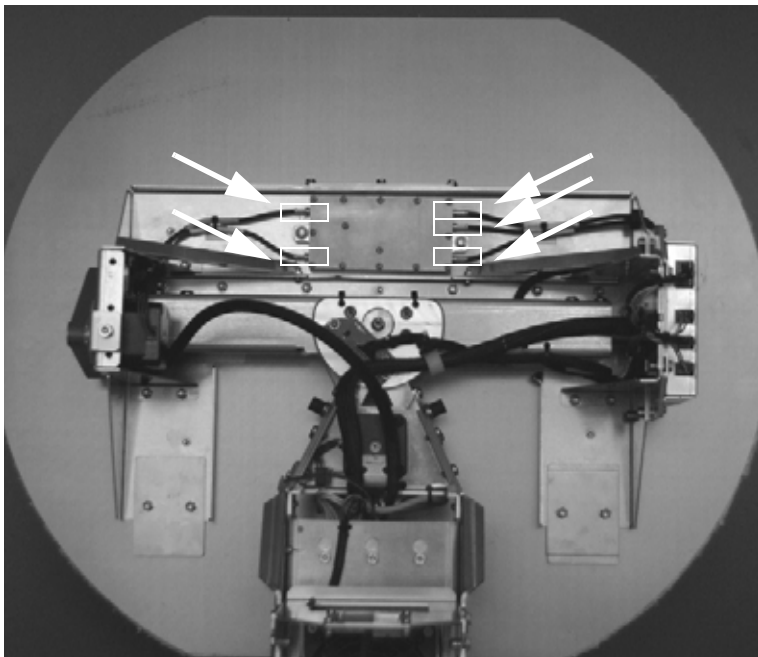

2. Unscrew the two hex nuts and gently remove the ATR module.

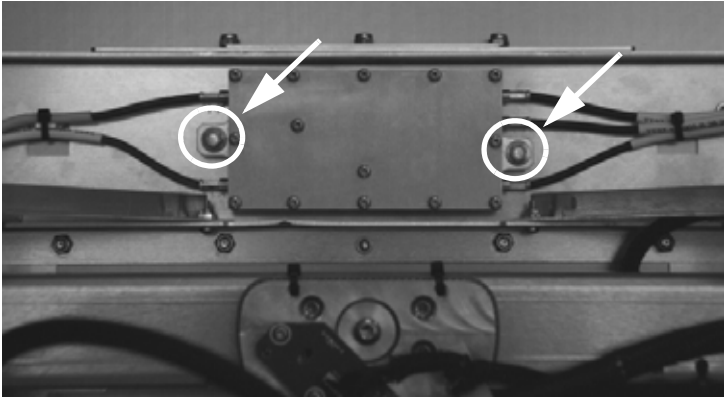

Mounting the ATR module

To mount the new ATR module, repeat the above procedure in reverse:

1. Fit the module on the studs on the antenna and fasten the hex nuts with a torque of 1.2 Nm.
2. Reconnect the plugs. Make sure the plugs are connected to the right connectors on the antenna, and that they are fitted properly. You should hear a click when the plug is fully inserted.

6.3.5 GPS module

Removing the GPS module

To remove the GPS module from the antenna, do as follows:

1. Disconnect the plug from the GPS module (indicated by white arrow). The GPS module is attached to the bottom of the mounting plate.

Important

Remember to release connector latches on the connector.

Do **not** pull the wires - pull the plug.

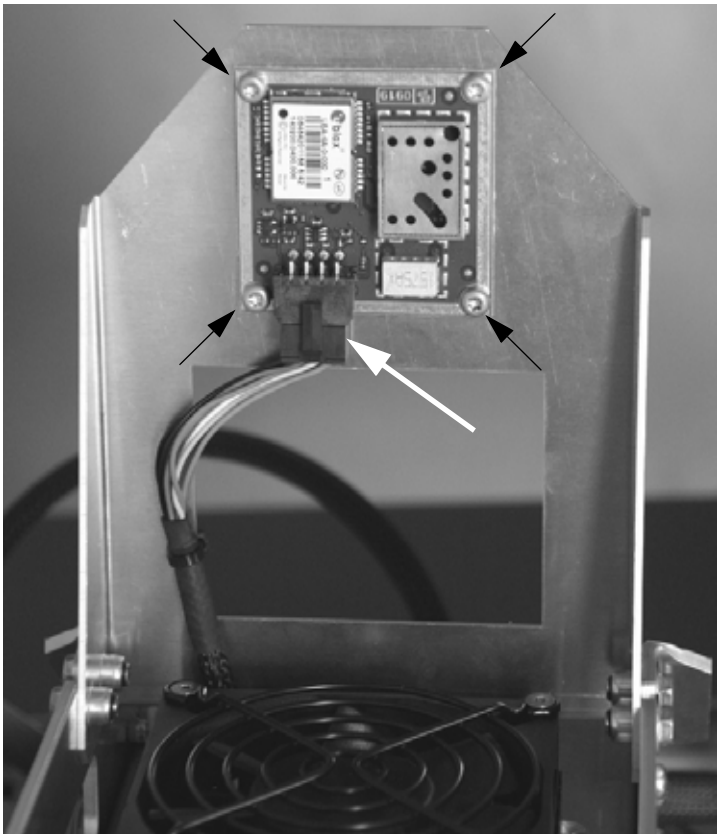

2. Unscrew the four screws on the GPS module with a torx screwdriver no. 10 and remove the module.

The position of the screws are indicated in the drawing on the previous page.

Mounting the GPS module

To mount the new GPS module, repeat the above procedure in reverse:

1. Fit the GPS module under the dedicated four holes on the mounting plate. See the drawing in the previous section.
2. Mount the four screws through the holes in the corners of the GPS module and fit the four hex nuts. Fasten the screws with torque 1.0 Nm using a torx screwdriver and a wrench.
3. Reinsert the plug. Make sure the plug is fitted properly.

6.3.6 Antenna Tracking Module

Removing the ATM module

To remove the ATM module from the antenna, do as follows:

1. Unscrew the three screws holding the sensor PCB.

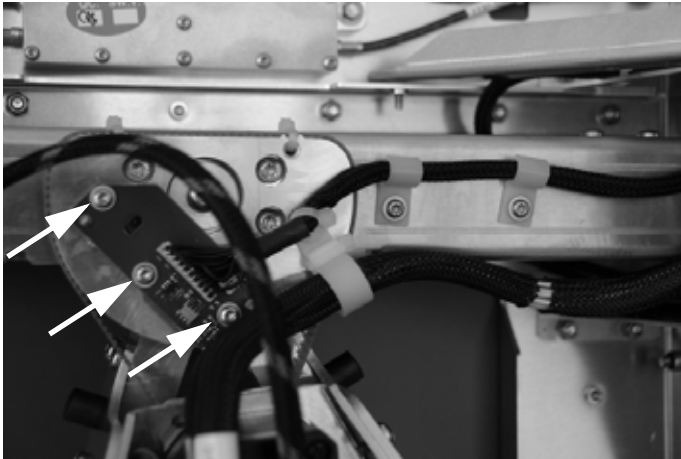

2. Cut the two cable ties (a and d), gently lift the two cable holders (b and c) as shown on the image below and release the cable.

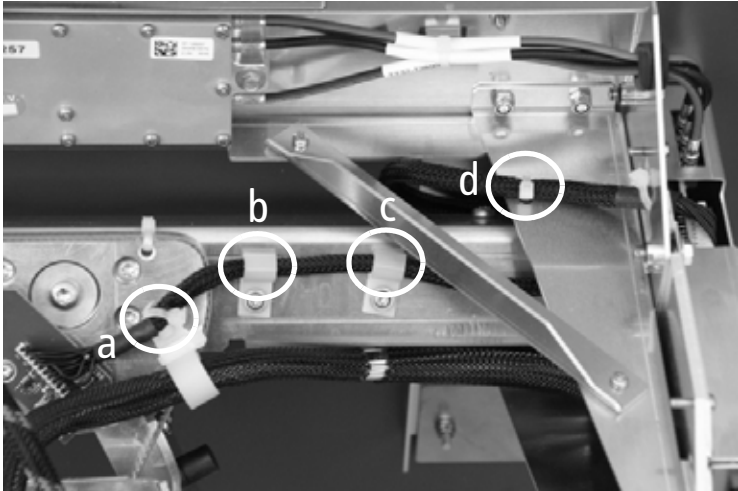

3. Disconnect the seven plugs indicated in the image below.

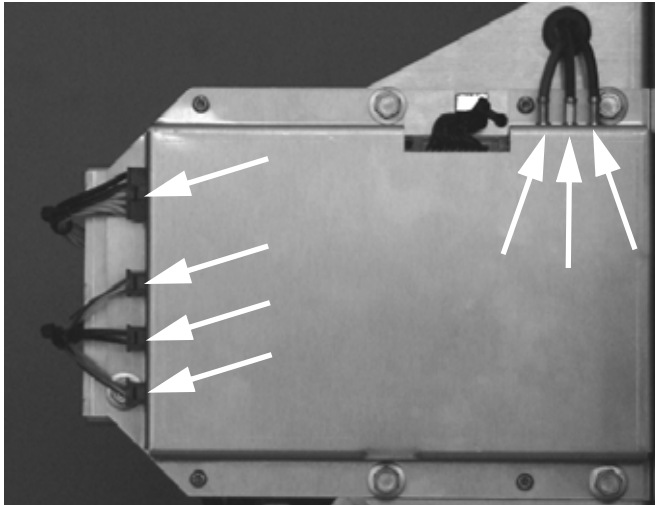

Important

Remember the exact position of each plug, so you do not connect to the wrong connector when installing the new module.

Remember to release connector latches on the connectors.

Do **not** pull the wires - pull the plugs.

4. Unscrew the six hex screws shown on the drawing below, and remove the ATM module and gently slide the sensor PCB through the slot underneath the ATM module.

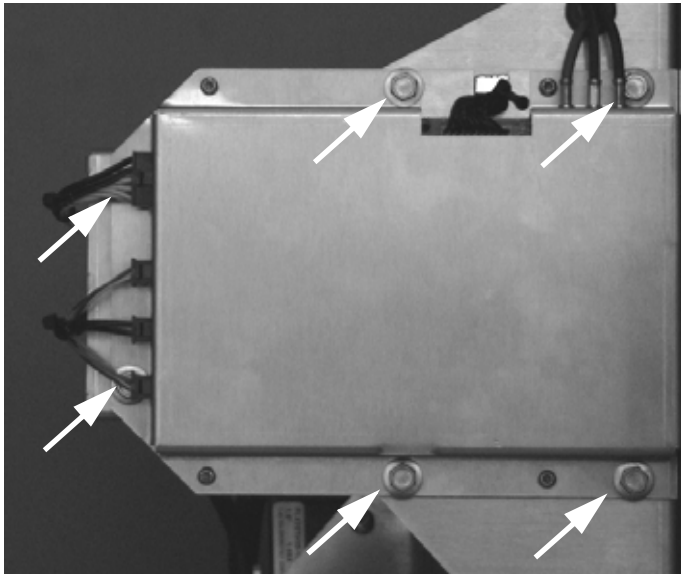

Mounting the ATM module

To mount the new ATM, repeat the above procedure in reverse:

1. Slide the sensor PCB through the slot.
2. Fit the six Hex screws on the ATM. Fasten the screws with 1.2 Nm torque.
3. Reconnect the plugs. Make sure the plugs are fitted properly. You should hear a click when the plug is fully inserted.
4. Turn the sensor PCB so that the cable can be positioned naturally as shown in the image below.

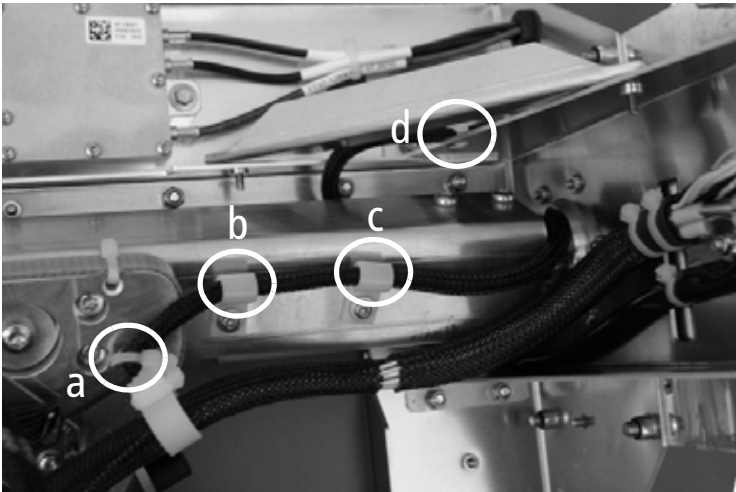

5. Gently lift the two cable holders (b and c) and fit the cable in them and mount the three screws with torque 1.0 Nm.
6. Refit the two cable ties (a and b), and make sure the antenna can move freely, without the sensor PCB cable obstructing the movement.

Troubleshooting

7.1 Reset button

7.1.1 How to access the Reset button

The terminal has a Reset button placed next to the SIM slot behind the SIM cover. The functions of this button is described in the next section.



To press the Reset button, use a pointed device.

7.1.2 Functions of the Reset button

The Reset button on the terminal has the following functions:

Action	Function
With the terminal running, press the Reset button normally.	<p>The terminal IP address and IP netmask are temporarily set to the default value (default IP address: 192.168.0.1).</p> <p>With this function, even if the IP address has been changed and you do not remember the new IP address, you can still access the web interface and see your current configuration. The default value is not saved in the configuration, but is only valid until next reboot.</p>
With the terminal running, press and hold the Reset button for 30 seconds, until the Power indicator on the terminal is flashing orange.	The terminal restores factory settings and reboots the system.

Action	Function
<p>While the terminal is booting, press and hold the Reset button.</p>	<p>For service use only!</p> <p>The bootloader initiates software upload. This firmware upload procedure is only to be used if the other procedures fail due to missing or corrupted firmware.</p> <p>This setup uploads software to the terminal from a TFTP server via the LAN connection. The procedure is as follows:</p> <ol style="list-style-type: none">1. Activate or install a TFTP server on a PC.2. Locate the correct software image (xxx.dl) for the terminal and place it in the TFTP server directory.3. Rename the image to ttexp.dl.4. Reconfigure the PC LAN interface to use the static address 192.168.0.2/255.255.255.0.5. Power off the terminal.6. Connect the PC LAN Interface to the terminal.7. Press and hold down the Reset button.8. Keep the Reset button pressed while powering on the terminal, and through the next step.9. Monitor the TFTP server window. When the upload starts you can release the Reset button.10. When the TFTP upload finishes the terminal boots up using the new image.

7.2 Status signaling

7.2.1 Overview

The SAILOR FleetBroadband system uses event messages and light indicators to display the status of the system.

7.2.2 Light indicators

Overview

The terminal has a number of light indicators, placed in the LED panel of the terminal:

- a green/orange Power indicator,
- a green/red/orange Terminal indicator,
- a green/red/orange Antenna indicator,
- a green Message indicator and
- 3 LAN indicators for each LAN interface, showing Activity (Green), Link/Speed (Green/Yellow) and PoE (Green/Red).



General status indicator functions



Power indicator

Behavior	Meaning
Steady green	Power OK.
Flashing green	The terminal is powering up.
Flashing orange	The terminal is shutting down.
Off	No power.

Terminal indicator

Behavior	Meaning
Steady green	Ready. BGAN registration completed.
Flashing green	Please wait - process in progress. BGAN registration ongoing.
Orange	Warning - temporary malfunction. User action is required.

Behavior	Meaning
Red	Critical error. Check the event log. If the problem is in the SAILOR FleetBroadband system and you cannot solve it, contact your distributor and return the unit for repair.

Antenna indicator

Behavior	Meaning
Steady green	Tracking. The antenna is ready for use.
Flashing green	Please wait - process in progress. Slow flashing: The antenna is starting up Rapid flashing: Sky scan
Orange	Warning - temporary malfunction. User action is required.
Red	Critical error. Check the event log in the web interface. If the problem is in the SAILOR FleetBroadband system and you cannot solve it, contact your distributor and return the unit for repair.

Message indicator

Behavior	Meaning
Flashing green	A new SMS message has arrived.

Behavior	Meaning
Off	No new messages, or the unit is off.

LAN indicator functions

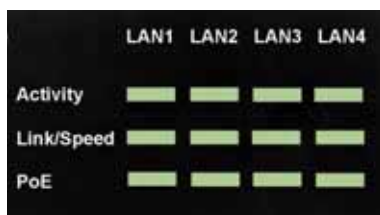

Activity indicator

Behavior	Meaning
Flashing green	The LAN port is active.

Link/Speed indicator

Behavior	Meaning
Green	Link speed is 100 Mbps.
Yellow	Link speed is 10 Mbps.
Off	The link is down.

PoE indicator

Behavior	Meaning
Green	The terminal is supplying power to the LAN port.
Red	The connected device requires more power than the terminal can supply to the LAN port.
Off	The terminal is not supplying power to the port.

7.2.3 Event messages

Display of event messages

The terminal can detect events during

- **POST** (Power On Self Test)
 - a self test performed at every power-up,
- **PAST** (Person Activated Self Test)
 - a self test performed when you click the **Self test** button under **Help desk** in the web interface, or
- **CM** (Continuous Monitoring)
 - continuous monitoring while the system is in operation.

When the terminal detects an event that requires your action, it issues an event message.

When your terminal issues an event message, the Terminal indicator or the Antenna indicator in the LED panel on top of the terminal signals the event, according to the tables



Terminal indicator and *Antenna indicator* in the previous section.

You can see the active event messages in the web interface by clicking the warning symbol in the icon bar at the top in the web interface.

All events are logged in the event log. For information on the event log, see *Event log* on page 120.

7.3 Logging of events

7.3.1 Diagnostic report

The diagnostic report contains information relevant for the service personnel during troubleshooting. When contacting Thrane & Thrane A/S for support, please include a diagnostic report.

To generate the diagnostic report, access the web interface and select **Help Desk**. Then click **Generate report**.

7.3.2 Event log

The event log holds information of all registered events in the terminal or antenna that are also shown in the Antenna and Terminal LEDs on the terminal.

The log includes the time of the occurrence, a short description, location of the error etc. This information can help troubleshooting errors in the system. You can see the event log in the web interface. For further information on the web interface, see the user manual for the SAILOR FleetBroadband systems.

Part numbers

A.1 System units

A.1.1 TT-3740A SAILOR 500 FleetBroadband system

Item	Part number
SAILOR 500 FleetBroadband antenna	403052A, 403052B or 403052C
SAILOR FleetBroadband terminal or SAILOR FleetBroadband 19" Rack Terminal	403738A or 403738A-T19

A.1.2 TT-3742A SAILOR 250 FleetBroadband system

Item	Part number
SAILOR 250 FleetBroadband antenna	403050A
SAILOR FleetBroadband terminal or SAILOR FleetBroadband 19" Rack Terminal	403738A 403738A-T19

A.1.3 TT-3670A Thrane IP Handset & Cradle, wired

Item	Part number
Thrane IP Handset, wired	403672A

Item	Part number
Thrane IP Cradle, wired	403674A

A.2 Spare parts

For information on available spare parts, do as follows:

1. Log on to the Thrane & Thrane Extranet.
2. Select eShop from the menu.

-or click this link <http://shop.thrane.com>. You may be asked to enter your user name and password for the Extranet.

Technical specifications

B.1 Overview

This chapter contains specifications for the SAILOR 500 FleetBroadband system and the SAILOR 250 FleetBroadband system including the terminal and antenna.

Note

For specifications and outline drawings for the Thrane IP Handset, refer to the manual for the IP handset.

B.2 SAILOR 500 FleetBroadband antenna

B.2.1 General specifications

Item	Specification
Type	BGAN Class 8, maritime mechanical tracking antenna
Rx Freq. Band Tx Freq. Band	1525.0 - 1559.0 MHz 1626.5 - 1660.5 MHz
Channel Spacing	1.25 kHz
Antenna element	Gain (RX-band, min.): 17.8 dBi Gain (TX-band, typical): 17.8 dBi
G/T	$G/T \geq -7$ dBK
EIRP	Min. EIRP: 10 dBW Max. EIRP: 23 dBW
Return loss	Better than -12 dB/50 Ω

Item	Specification
Cable losses	RF attenuation: at 1660 MHz: max. 20 dB at 54 MHz: max. 4 dB at 36 MHz: max. 3 dB DC resistance (loop): max. 1 Ω Max. cable length, terminal to antenna: <ul style="list-style-type: none"> • RG223-D: 25 meter • RG214/U: 50 meter • S 07272B-05: 95 meter
Antenna input voltage	28 V
Antenna power, operational	56 W
Total antenna weight	TT3052A antenna: 16 kg TT3052B antenna: 19 kg TT3052C antenna: 23 kg
Antenna dimensions	TT3052A antenna: 605 mm x \varnothing 630 mm TT3052B antenna: 655 mm x \varnothing 630 mm TT3052C antenna: 797.5 mm x \varnothing 687 mm

B.2.2 Environmental specifications

Item	Specification
Water and dust	IPX6 spray proof in all directions according to IEC 60529 and IEC 60945, no dust test.
Ambient Temperature	Operational: -25° to +55°C Storage: -40° to +80°C
Operating humidity	100%, condensing
Ice, survival	Up to 25 mm of ice
Wind	Normal operation with relative average wind velocity up to 200 km/h (56 m/s, 108 knots).
Vibration, operational	Random spectrum 1.05 g rms x 3 axes: 5 to 20 Hz: 0.02 g ² /Hz 20 to 150 Hz: -3 dB/octave Sine: 2 to 13.2 Hz: ± 1 mm 13.2 to 100 Hz: 7 m/s ² 2 h dwell at resonances
Vibration, non-operational	Random spectrum 1.7 g rms 2 h x 3 axes 6 h total): 5 to 20 Hz: 0.05 g ² /Hz 20 to 150 Hz: -3 dB/octave

Item	Specification
Ship motions: (MAX)	Roll: 30°, period 4 sec., 0.7 g tangential Pitch: 15°, period 3 sec., 0.6 g tangential Yaw: 10°, period 5 sec., 0.3 g tangential Surge: 0.5 g Sway: 0.5 g Heave: 0.7 g Turning rate: 36°/s; Acceleration 12°/s ² Headway: 22 m/s (42 knots)
Shock	Half sine, 20 g/11 ms
Solar radiation	1120 W/m ² according to MIL-STD-810F 505.4
Air Pressure, operational	1500 m AMSL
Air Pressure, transport	4572 m AMSL MIL-SPEC 810E 500.4
Equipment category	Exposed to the weather - IEC-60945

B.2.3 Antenna outline dimensions

TT-3052A antenna

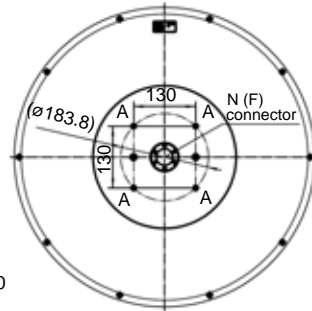

A: 4 pcs. M10

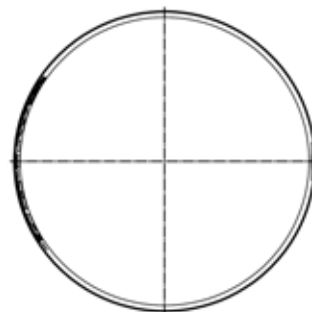
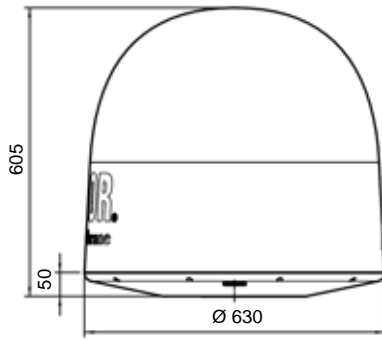
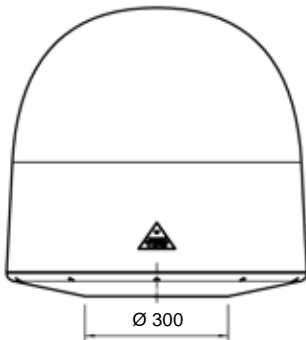

Weight: 16 kg.

Dimensions are in mm.

TT-3052B antenna

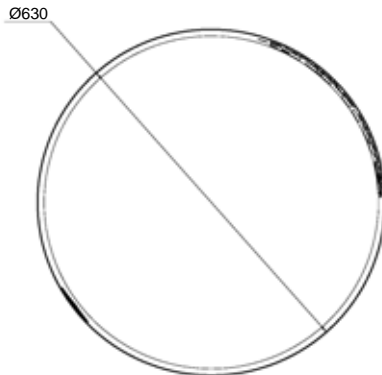
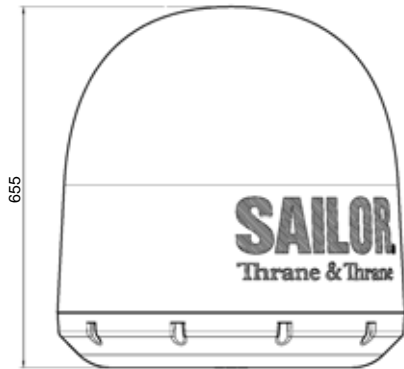
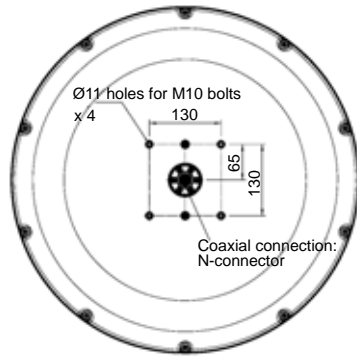

Weight: 19 kg.

Dimensions are in mm.

TT-3052C antenna

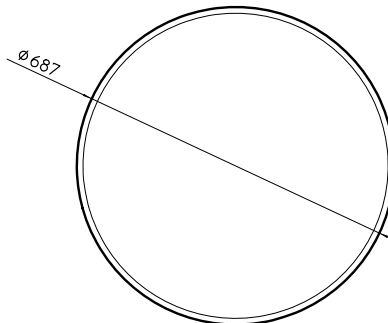
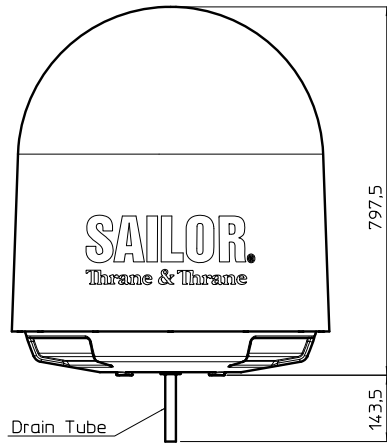
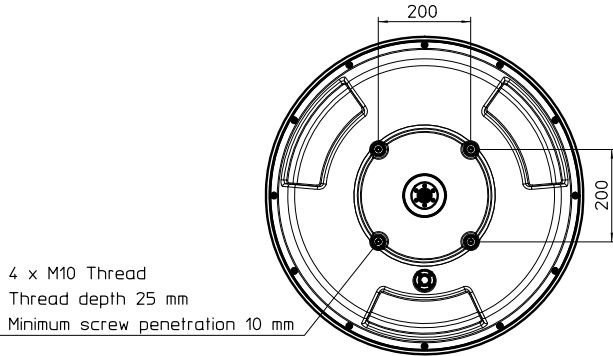

Weight: 23 kg.
Dimensions are in mm.

B.2.4 Outline dimensions, SAILOR 500 flange

The below drawings show the dimensions for a flange used for mounting the SAILOR 500 FleetBroadband antenna on a mast.

Flange for TT-3052A/B antenna

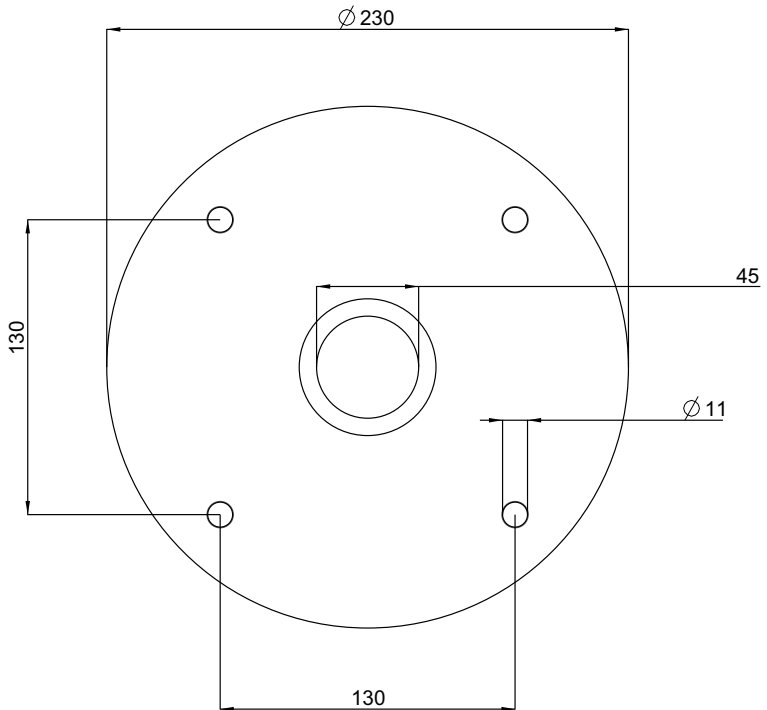

Dimensions are in mm.

Flange for TT-3052C antenna

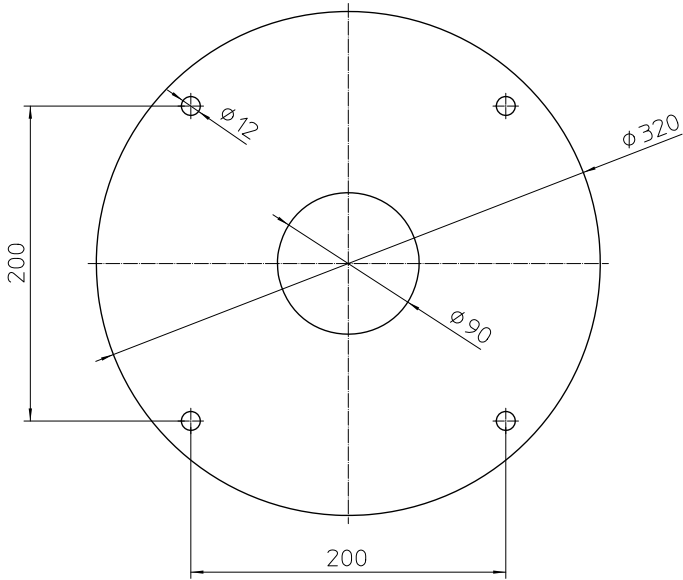

Dimensions are in mm.

B.3 SAILOR 250 FleetBroadband antenna

B.3.1 General specifications

Item	Specification
Rx Freq. Band	1525.0 - 1559.0 MHz
TX Freq. Band	1626.5 - 1660.5 MHz
Channel spacing	1.25 kHz
Antenna element gain Rx	11.0 dB min.
G/T	≥ -15.5 dB/K
EIRP	Min. EIRP: 3.1 dBW Max. EIRP: 16.1 dBW
Return loss	< -15 dB (reflection loss < 0.15 dB)
Cable losses	RF attenuation: max. 20 dB DC resistance (loop): max. 1 Ω Max. cable length between terminal and antenna: <ul style="list-style-type: none"> • RG223-D: 25 meter • RG214/U: 50 meter • S 07272B-05: 95 meter
Antenna input voltage	22.7 V

Appendix B: Technical specifications

Item	Specification
Antenna power, operational	Maximum 39 W
Total antenna weight	3.9 kg (8.6 lbs)
Antenna dimensions	329.2 mm x 275.6 mm

B.3.2 Environmental specifications

Item	Specification
Water and dust	IPX6 spray proof in all directions, no dust test.
Ambient Temperature	Operational: -25° to +55°C Storage: -40° to +85°C
Operating humidity	100%, condensing
Ice, survival	Up to 25 mm of ice
Wind load, max.	Normal operation with relative average wind velocity up to 200 km/h (56 m/s, 108 knots)
Vibration, operational	Random spectrum 1.05 g rms x 3 axes: 5 to 20 Hz: 0.02 g ² /Hz 20 to 150 Hz: -3 dB/octave Sine: 2 to 13.2 Hz: ± 1 mm 13.2 to 100 Hz: 7 m/s ² 2 h dwell at resonances
Vibration, non-operational	Random spectrum 1.7 g rms 2 h x 3 axes 6 h total): 5 to 20 Hz: 0.05 g ² /Hz 20 to 150 Hz: -3 dB/octave

Item	Specification
Vibration, life test	At least 1.7 g rms for 2 hours pr. axis. Spectrum: 5 to 20 Hz: 0.05 g ² /Hz, 20 to 150 Hz: -3 dB/octave
Shock	Half sine, 20 g/11 ms
Solar radiation	1120 W/m ² according to MIL-STD-810F 505.4
Air Pressure, operational	1500 m AMSL
Air Pressure, transport	4572 m AMSL MIL-SPEC 810E 500.4
Ship motions (MAX)	Roll: 30°, period 4 sec., 0.7 g tangential Pitch: 15°, period 3 sec., 0.6 g tangential Yaw: 10°, period 5 sec., 0.3 g tangential Surge: 0.5 g Sway: 0.5 g Heave: 0.7 g Turning rate: 36°/s; 12°/s ² Headway: 22 m/s (42 knots)

B.3.3 Antenna outline dimensions

SAILOR 250 FleetBroadband antenna

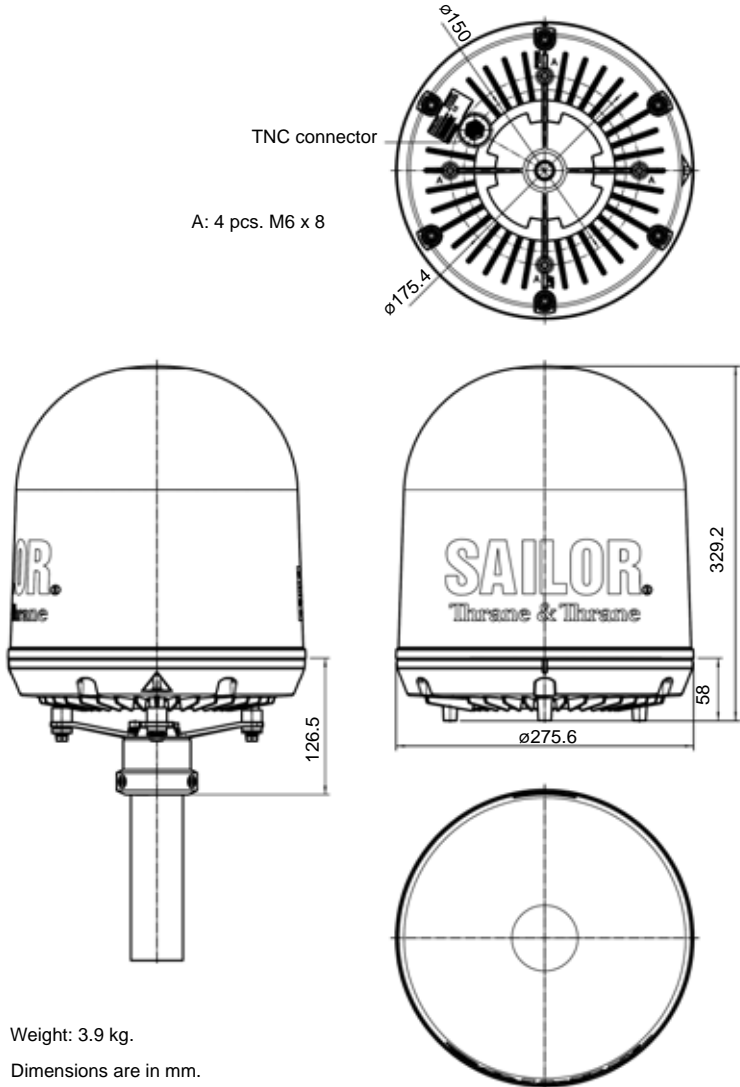

A: 4 pcs. M6 x 8

Weight: 3.9 kg.

Dimensions are in mm.

B.4 Minimum distance to transmitters

The table below shows the minimum recommended distance to transmitters in the frequency range below 1000 MHz.

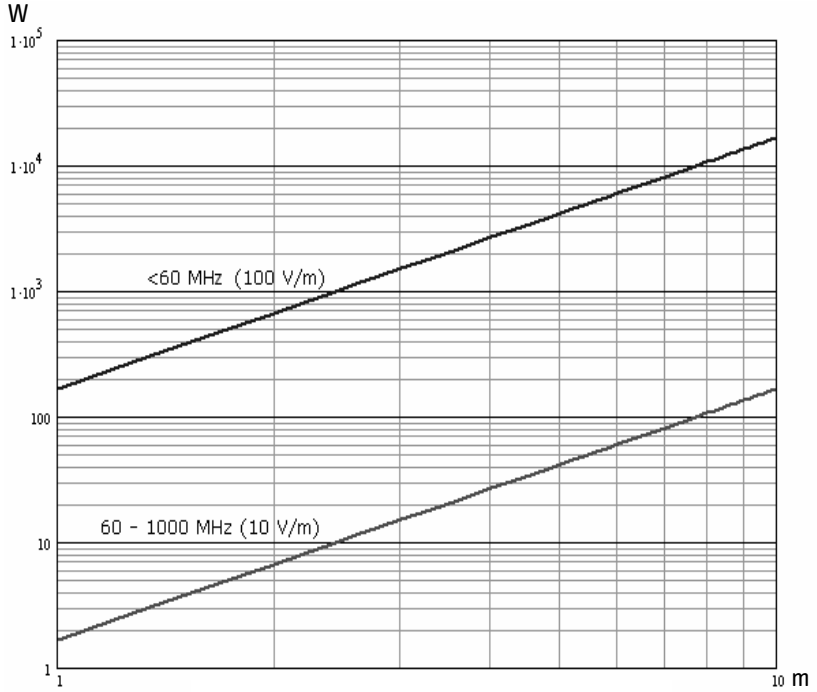

Recommended distance to SAILOR FleetBroadband antenna.

B.5 SAILOR FleetBroadband terminal

B.5.1 General specifications (including 19" rack version)

Item	Specification										
Weight	SAILOR FleetBroadband terminal: 2.5 kg (5.5 lbs) SAILOR FleetBroadband 19" Rack Terminal: 5 kg (11 lbs)										
Dimensions	SAILOR FleetBroadband terminal: 264.5 mm x 273 mm x 42.5 mm (10.4" x 10.7" x 1.7") SAILOR FleetBroadband 19" Rack Terminal: 342.3 mm x 482.6 mm x 43.65 mm (13.5" x 19" x 1.7")										
Global services	<table border="0"> <tr> <td data-bbox="188 954 244 986">Voice</td> <td data-bbox="407 954 740 986">4 kbps AMBE+2 or 3.1 KHz Audio</td> </tr> <tr> <td data-bbox="188 1002 236 1034">Data</td> <td data-bbox="407 1002 661 1034">SAILOR 500: 64 kbps UDI</td> </tr> <tr> <td data-bbox="210 1066 325 1098">Standard IP</td> <td data-bbox="407 1066 678 1129">SAILOR 500: 432/432 kbps, SAILOR 250: 284/284 kbps</td> </tr> <tr> <td data-bbox="210 1161 342 1193">Streaming IP</td> <td data-bbox="407 1161 813 1225">SAILOR 500: 8, 16, 32, 64, 128, 256 kbps, SAILOR 250: 8, 16, 32, 64, 128 kbps</td> </tr> <tr> <td data-bbox="188 1241 236 1273">SMS</td> <td data-bbox="407 1241 613 1273">Up to 160 characters</td> </tr> </table>	Voice	4 kbps AMBE+2 or 3.1 KHz Audio	Data	SAILOR 500: 64 kbps UDI	Standard IP	SAILOR 500: 432/432 kbps, SAILOR 250: 284/284 kbps	Streaming IP	SAILOR 500: 8, 16, 32, 64, 128, 256 kbps, SAILOR 250: 8, 16, 32, 64, 128 kbps	SMS	Up to 160 characters
Voice	4 kbps AMBE+2 or 3.1 KHz Audio										
Data	SAILOR 500: 64 kbps UDI										
Standard IP	SAILOR 500: 432/432 kbps, SAILOR 250: 284/284 kbps										
Streaming IP	SAILOR 500: 8, 16, 32, 64, 128, 256 kbps, SAILOR 250: 8, 16, 32, 64, 128 kbps										
SMS	Up to 160 characters										

Item	Specification
Antenna interface	One connector, TNC-female 1525 to 1559 MHz: -94 dBm to -64 dBm 1626.5 to 1660.5 MHz: -9 dBm to +11 dBm Power supply: 18-29 V DC
2-wire telephone interface	Two connectors: RJ-11 female. 600 Ω ITU-T Rec. G.473, standard DTMF telephone. Supported cable length: up to 100 meters.
ISDN interface	One connector: RJ-45 female. Conforms with CCITT I.430, ETSI ETS300012, ANSI T1.605.
LAN interface	Four connectors: RJ-45 female. Conforms with IEEE 802.3 af, 10/100 Mbps. Supported cable length: up to 100 m PoE (max. 15.4 W) on each port, Total PoE power: 64 W at 24 V operation, 32 W at 12 V.

Item	Specification
<p>I/O interface</p> <p>Output:</p> <p>Open switch hold-off voltage</p> <p>Open circuit resistance</p> <p>Closed switch voltage</p> <p>Input:</p> <p>Input resistance</p> <p>Voltage</p> <p>Voltage High</p> <p>Voltage Low</p>	<p>One connector with 5 configurable inputs/outputs.</p> <p>Open collector, Short circuit protected at 1.5 A and reverse polarization protected.</p> <p>max. 32 V</p> <p>min. 130 KΩ</p> <p>max. 1 V DC at 50 mA</p> <p>min. 130 KΩ</p> <p>Max. 32 V</p> <p>Min. 2.2 V</p> <p>Max. 1.2 V</p>
<p>L-Band output</p>	<p>One connector: SMA female.</p> <p>Rx output, 1525 - 1559 MHz: -105 dBm to -80 dBm</p>
<p>Power Input</p>	<p>Connector: Mixed D-Sub 7W2</p> <p>Nominal 12/24 VDC (10.5 - 32 V DC; 14 A - 5.5 A)</p> <p>Max. source impedance: 85 mΩ at 12 V, 500 mΩ at 24 V</p> <p>Maximum 20 A at 24 V, 5 ms (start up)</p>
<p>Standby current</p>	<p>Ignition function, off: max. 15 mA</p> <p>Remote on/off in DC connector, off: max. 2 mA</p>
<p>Ambient temperature</p>	<p>Operational: -25° to +55°C</p> <p>Storage: -40° to +80°C</p>

Appendix B: Technical specifications

Item	Specification
Relative Humidity	95% non-condensing at +40°C
Equipment category	Protected from the weather - IEC-60945

B.5.2 Outline dimensions, SAILOR FleetBroadband terminal

Connector panel and bottom view, including Basic cable support.

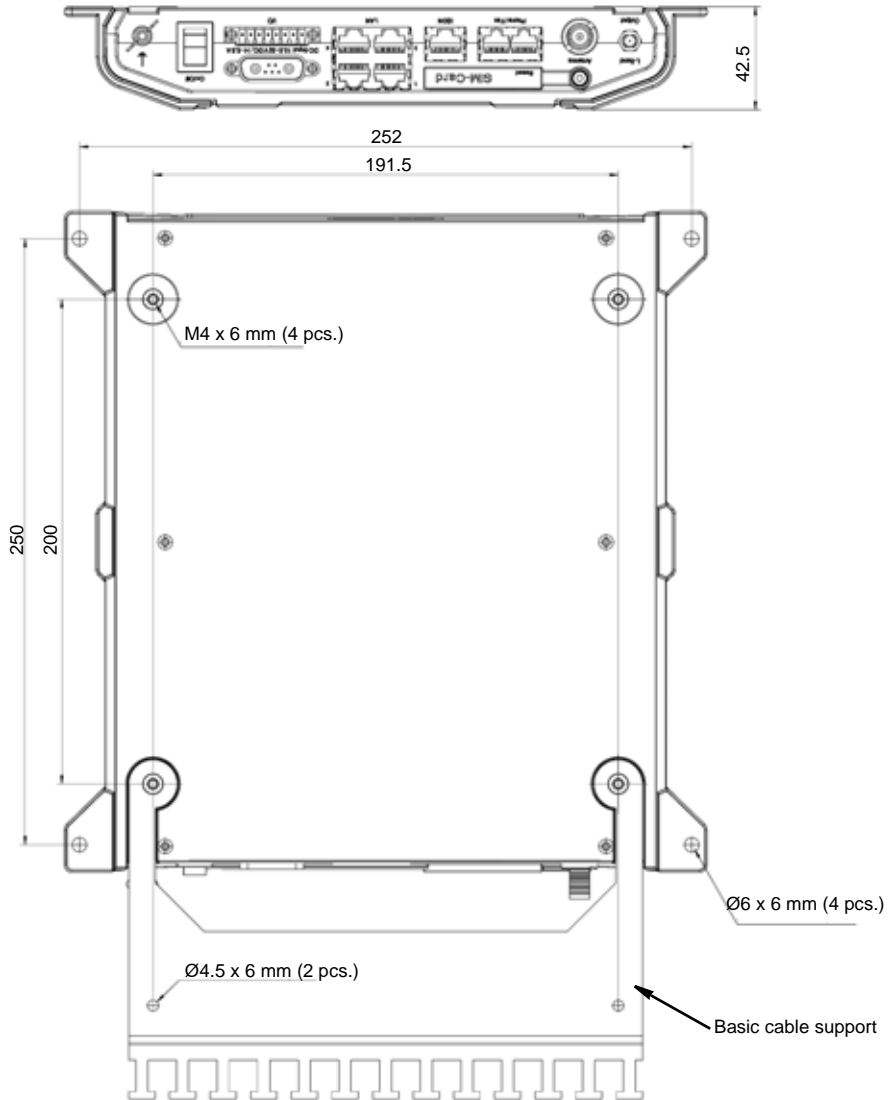

Side view and top view, including Basic cable support.

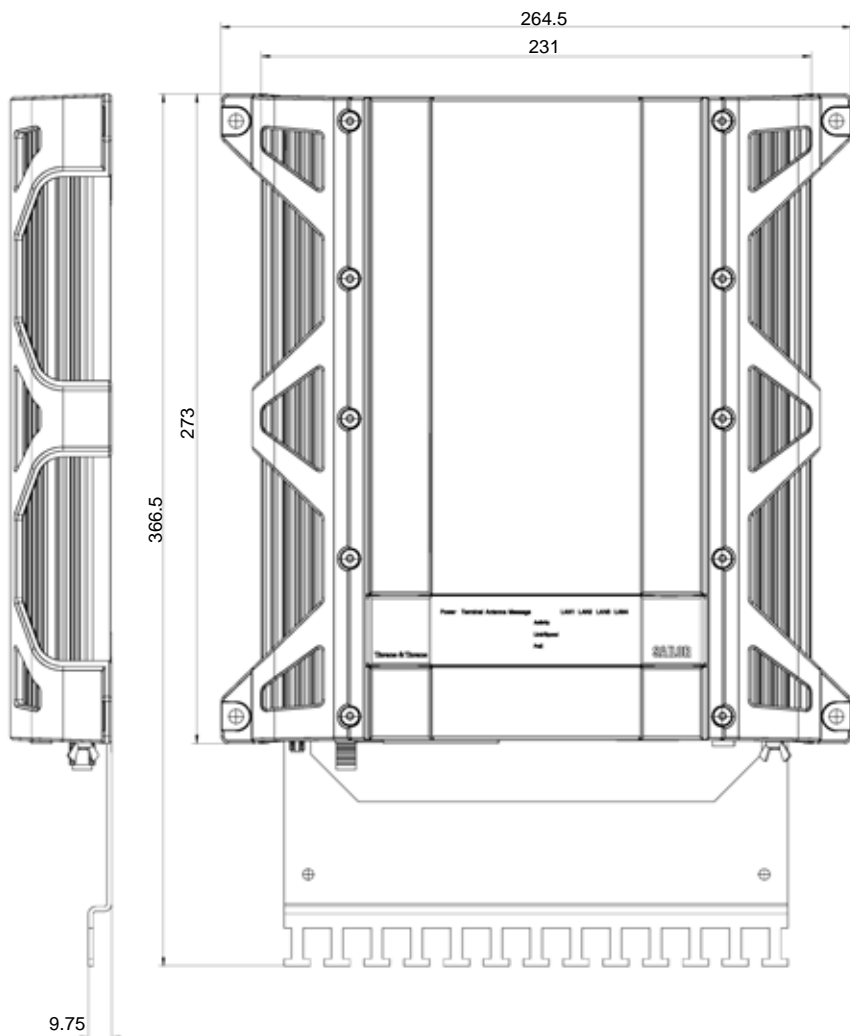

End view with serial number label and heat label.



Weight: 2.5 kg.

Dimensions are in mm.

B.5.3 Outline dimensions, 19" Rack Terminal

Front and top view, including Basic cable support.

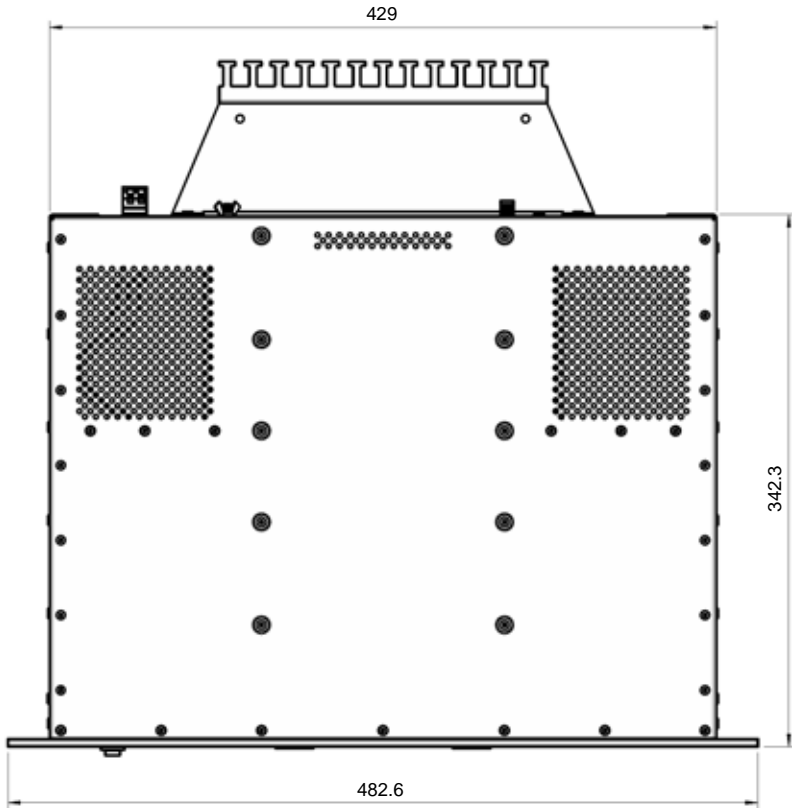

Connector panel, side view and perspective views, including Basic cable support.

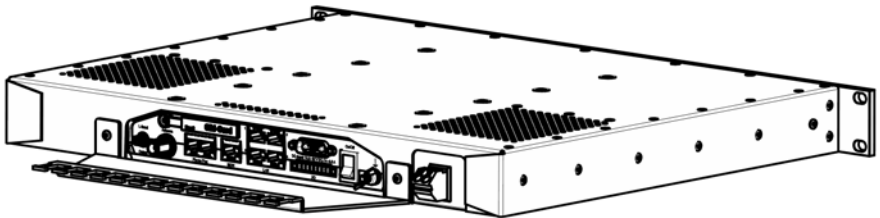
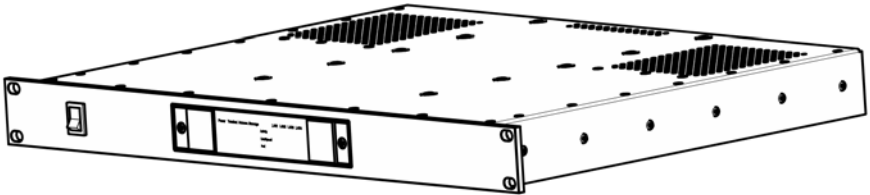
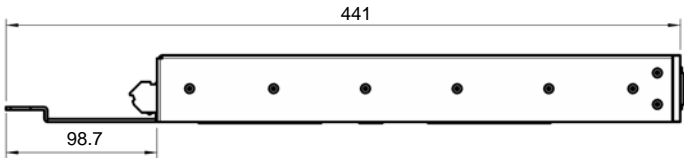

Weight: 5 kg.

Dimensions are in mm.

Grounding and RF protection

C.1 Why is grounding required?

C.1.1 Reasons for grounding

Grounding the TracPhone system is required for two reasons:

- Safety: Lightning protection of persons and equipment.
- Protection: ESD (ElectroStatic Discharge) protection of equipment.

C.1.2 Safety

First of all grounding of the system is required for safety reasons. In the event of a lightning strike at the antenna a proper grounding of the system will provide a low resistance path to divert the strike discharge to seawater.

C.1.3 ESD Protection

The ESD protection circuits in the terminal rely on proper grounding of the system in order to work properly. Otherwise sensitive circuits within the terminal might be damaged due to ESD when you are handling the equipment.

C.2 About marine DC systems

C.2.1 Wiring systems

Two basic wiring topologies are used for marine DC system grounding: **Two-Wire Return System** and **One Pole Grounded Return System**.

C.2.2 Two-wire Return System

This configuration implies that no part of the circuit, in particular the battery negative, is connected to any ground potential or equipment. The system is totally isolated and includes engine sensors, starter motors etc. This arrangement is preferred for steel and aluminum vessels.

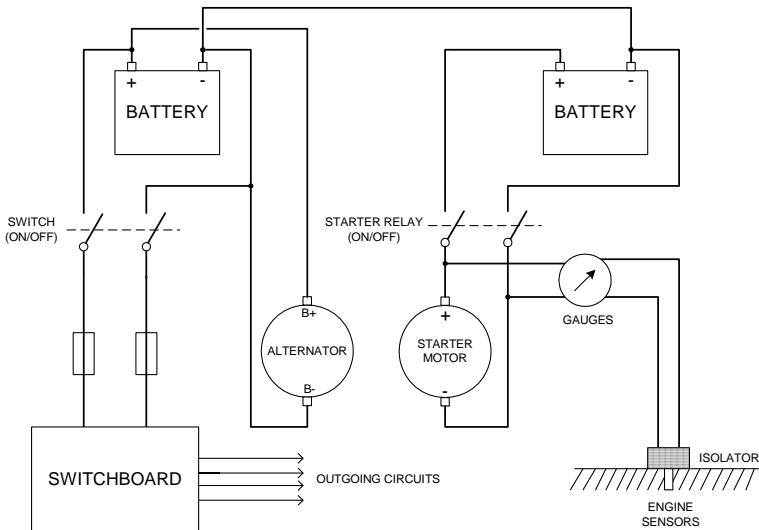

C.2.3 One Pole Grounded Return System

This configuration implies that the battery negative is bonded to a ground potential, typically at the engine negative terminal. This is done in order to polarize the DC electrical system.

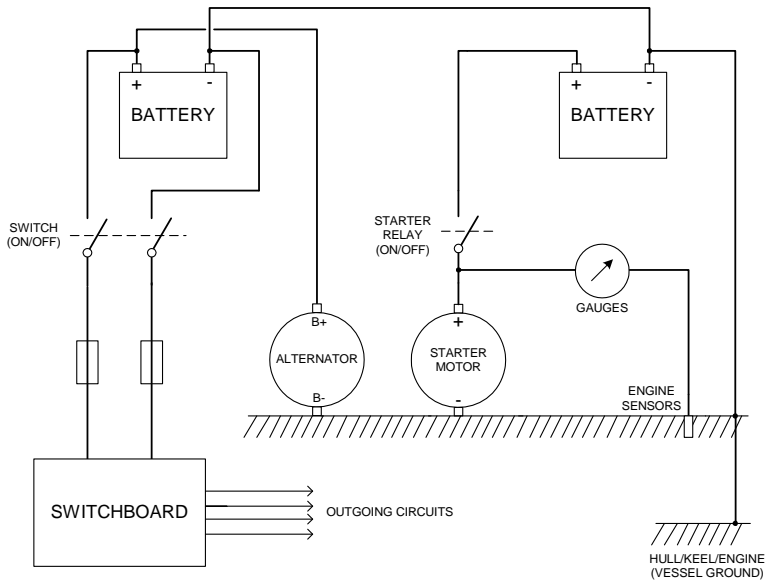

Note

This arrangement is not suitable for steel and aluminum vessels as this might cause electrolytic corrosion of the hull.

C.3 About marine grounding

There is great confusion about the different ground terms used when dealing with marine electrical installations. The various terms are listed below for reference.

Term	Definition
DC Negative	Actually not a ground but a current-carrying conductor which carries the same current that flows in the positive conductor. The DC Negative may be electrically connected to seawater (at one point only, via the engine negative terminal though the shaft and the propeller) or left completely floating.
Lightning Ground	Ground potential immersed in seawater. Provides a path to ground lightning strike energy. Please note that this is not a functional part of any other electrical system.
Corrosion System Ground	Bonding arrangement that ensures equal electrical potential for all dissimilar underwater metal parts and provides galvanic protection by means of sacrificial anodes.
AC Ground (Protective Earth)	Ground potential immersed in seawater (typically the hull for steel and aluminum vessels). Serves as safety ground (protective earth) thus preventing shocks or electrocution in the event of a fault situation.
RF Ground (Capacitive)	Underwater ground potential that is capacitively coupled to seawater ground. Typically numerous pieces of bonded underwater metal parts such as keel (isolated), water tank, engine block etc. will act as a capacitive RF ground (that is; no DC connection to seawater). Often referred to as “counterpoise” for the SSB/HF aerial system.

Term	Definition
RF Ground (Electrical)	Underwater ground potential that is electrically coupled to seawater ground by means of a separate ground plate (e.g. Dynaplate). Also referred to as “counterpoise” for the SSB/HF aerial system.

C.4 Grounding Recommendations

C.4.1 Grounding the terminal

The terminal should be grounded to the ship/hull. For this purpose you may use a short antenna cable and a grounding kit. A suitable grounding kit is available from Thrane & Thrane. Further, the terminal must be grounded at its grounding stud in order to ensure proper grounding if the short antenna cable is disconnected. For further information, see *Grounding the terminal* on page 33.

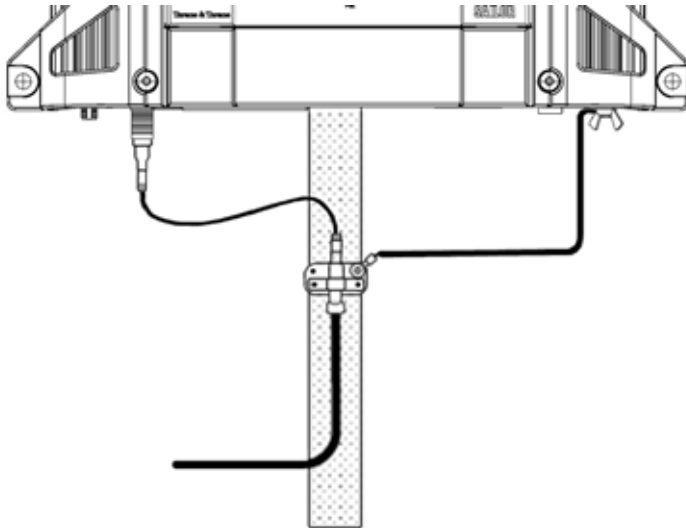

If you are using the Extended cable support, make the ground connections through the cable support.

You may need to extend the ground plane using copper foil. For further information, see *Extending the ground plane* on page 34.

C.4.2 Grounding the antenna

You can ground the antenna to the ship/hull via one or more of its mounting bolts. Make sure to remove painting, dirt, grease etc. at the mounting holes in order to make good electrical contact to the hull. Use serrated washers when securing the mounting bolts and seal the joint with protective coating to avoid corrosion.

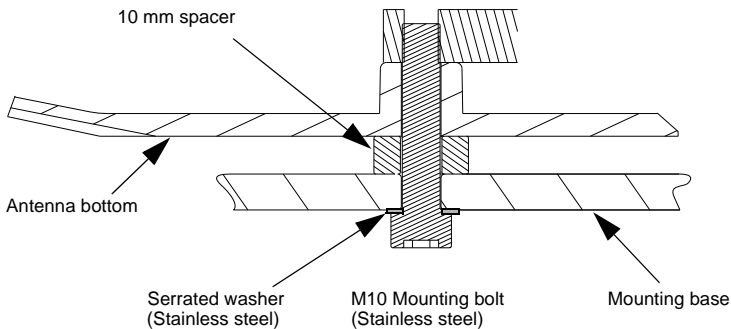

If you are using vibration isolators at the bolts, the grounding connection between the mounting surface and the bolts is not sufficient. In that case mount a separate grounding wire. See *Separate ground cable* on page 163.

It is always recommended to establish the shortest grounding path as possible e.g. on steel hulls the antenna should be grounded directly to the hull¹. However, due to the fact that this is not possible on e.g. fiberglass hulls (nor is it preferable on aluminum hulls) a number of alternative grounding methods are suggested in the following paragraphs.

1. Please note that the antenna ground connection is made at the same electrical ground potential as the terminal.

C.5 Alternative grounding for steel hulls

The following guidelines assume a two-wire, isolated grounding arrangement; that is no part of the circuit, in particular the battery negative, is connected to any ground potential or equipment.

C.5.1 Grounding the terminal

The terminal must be grounded to the ship with the short antenna cable and a grounding kit (available from Thrane & Thrane). Further, the terminal must be grounded at its grounding stud in order to ensure a proper grounding if the short antenna cable is disconnected.

The ground connection can be established either at the hull (recommended) or at a dedicated RF ground if available (alternative). However, bear in mind that the antenna ground connection is to be made at the **same electrical ground potential as the terminal** (see *Grounding the antenna*).

The terminal provides galvanic isolation (as required) from its input power terminals to the chassis/grounding stud. This way the isolated grounding arrangement is maintained.

C.5.2 Grounding the antenna

Terminal grounded at the hull (recommended)

In this case the antenna is grounded to the ship via one (or more) of its mounting bolts. Make sure to remove painting, dirt, grease etc. at the mounting holes in order to make good electrical contact to the hull. Use serrated washers when securing the mounting bolts and seal the joint with protective coating to avoid corrosion.

Terminal grounded at a dedicated RF ground (alternative)

In this case the antenna is grounded with a separate ground cable. The ground cable must be routed parallel and close to the shielded coax cable connecting the antenna to the terminal grounding kit. A tinned heavy gauge wire (min. 6 mm²) can be used for this purpose - see page 162.

Note

The antenna must be electrically isolated at its mounting bolts by means of shoulder bushings and washers ensuring the isolated RF ground - see page 165.

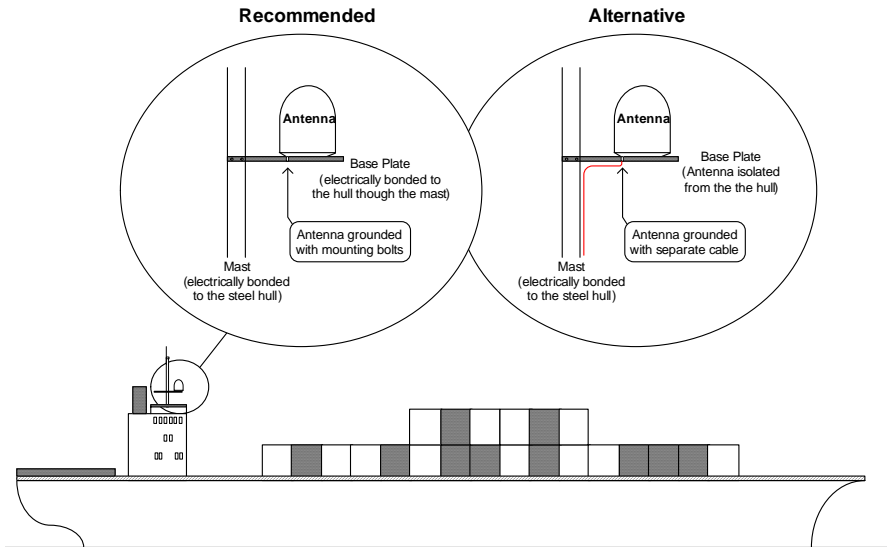

C.6 Alternative grounding for aluminum hulls

The following guidelines assume a two-wire, isolated grounding arrangement; that is no part of the circuit, in particular the battery negative, is connected to any ground potential or equipment.

C.6.1 Grounding the terminal

The terminal must be grounded with the short antenna cable and a grounding kit (available from Thrane & Thrane). Further, the terminal must be grounded at its grounding stud to ensure a proper grounding if the short antenna cable is disconnected.

The ground connection must be established at a dedicated RF ground (either capacitively or electrically coupled). Remember to make the antenna ground connection at the **same electrical ground potential** as the terminal (see *Grounding the antenna*).

The terminal provides galvanic isolation (as required) from its input power terminals to the chassis/grounding stud. This way the isolated grounding arrangement is maintained.

C.6.2 Grounding the antenna

If the mounting base of the antenna is electrically connected to the hull (or any other ground potential than the terminal), the antenna must be isolated at its mounting bolts by means of shoulder bushings and washers - see page 165. This is done in order to prevent DC currents flowing in the hull thus causing electrolytic corrosion.

However, a ground connection must be established via one of the mounting bolts using a separate ground cable. The ground cable must be routed parallel and in close proximity to the shielded coax cable hence connecting the antenna to the terminal Grounding kit. A tinned heavy gauge wire (min. 6 mm²) can be used for this purpose - see page 158.

Alternative grounding for aluminum hulls

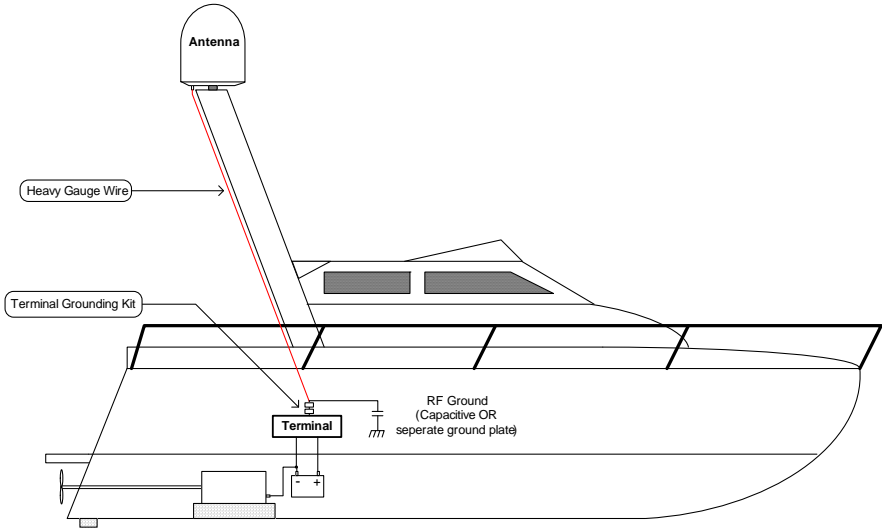

C.7 Alternative grounding for fiberglass hulls

C.7.1 Grounding the terminal

The terminal must be grounded with the short antenna cable and a grounding kit (available from Thrane & Thrane). Further, the terminal must be grounded at its grounding stud in order to ensure a proper grounding if the short antenna cable is disconnected.

The ground connection must be established at a dedicated RF ground (either capacitive or electrical coupled). Bear in mind that the antenna ground connection is to be made at the **same electrical ground potential** as the terminal (see *Grounding the antenna*).

C.7.2 Grounding the antenna

If the mounting base of the antenna is electrically connected to any other ground potential than the terminal (e.g. Lightning Ground), the antenna must be isolated at its mounting bolts by means of shoulder bushings and washers - see page 165.

However, a ground connection must be established via one of the mounting bolts using a separate ground cable. The ground cable must be routed parallel and in close proximity to the shielded coax cable hence connecting the antenna to the terminal Grounding kit. A tinned heavy gauge wire (min. 6 mm²) can be used for this purpose - see page 160.

Alternative grounding for fiberglass hulls

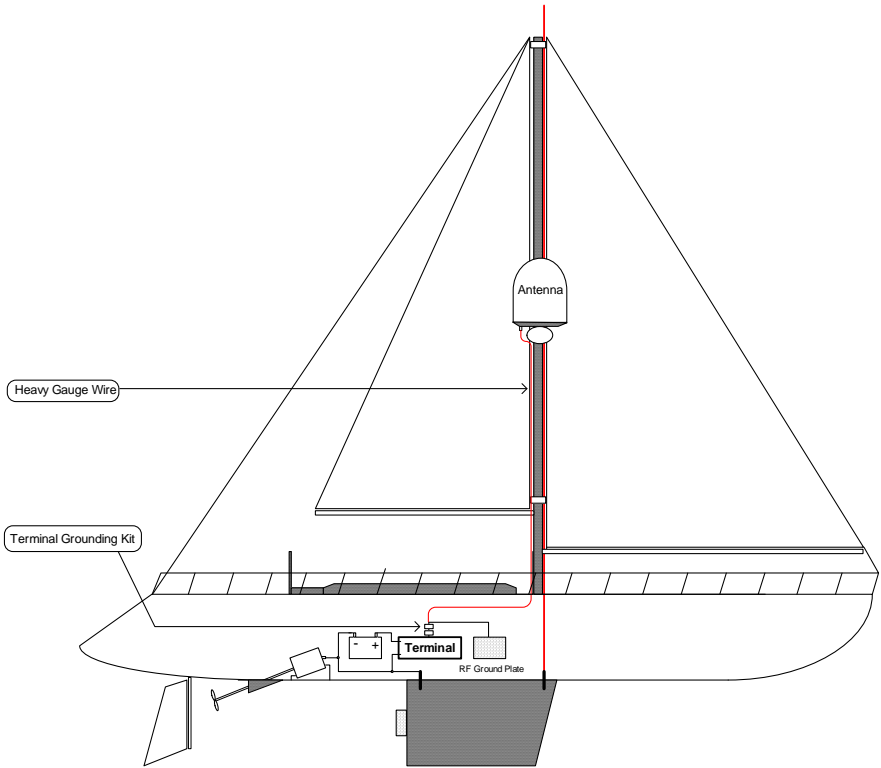

C.8 Alternative grounding for timber hulls

C.8.1 Grounding the terminal

The terminal must be grounded with the short antenna cable and the Grounding kit (accessories). Further, the terminal must be grounded at its grounding stud in order to ensure a proper grounding if the short antenna cable is disconnected.

The ground connection must be established at a dedicated RF ground (either capacitive or electrical coupled). Bear in mind that the antenna ground connection is to be made at the **same electrical ground potential** as the terminal (see *Grounding the antenna*).

C.8.2 Grounding the antenna

If the mounting base of the antenna is electrically connected to any other ground potential than the terminal (e.g. Lightning Ground), the antenna must be isolated at its mounting bolts by means of shoulder bushings and washers - see page 165.

However, a ground connection must be established via one of the mounting bolts using a separate ground cable. The ground cable must be routed parallel and in close proximity to the shielded coax cable hence connecting the antenna to the terminal Grounding kit. A tinned heavy gauge wire (min. 6 mm²) can be used for this purpose - see page 162.

Alternative grounding for timber hulls

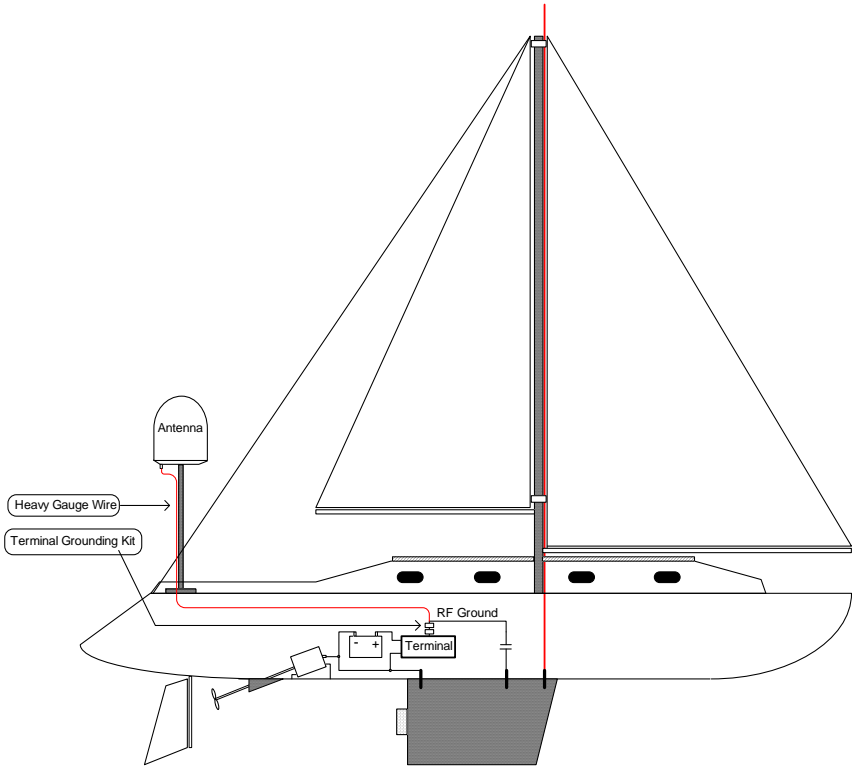

C.9 Separate ground cable

C.9.1 Ground cable - construction

When dealing with electrical installations in a marine environment, all wiring must be done with double insulated, tinned, high quality and if exposed also UV resistant cables. This shall also apply to the separate ground cable mentioned in the previous paragraphs.

The ground cable is constructed using an appropriate cable with a cross section area of at least 6 mm^2 (AWG10) and terminated with insulated ring crimp terminals – see illustration below. The crimp terminals must be a marine approved type e.g. the DuraSeal series from Raychem.

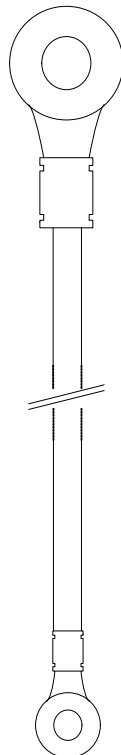

Antenna:
M10 Insulated Ring Terminal
(Raychem, DuraSeal Series)

Terminal:
M4 Insulated Ring Terminal
(Raychem, DuraSeal Series)

C.9.2 Ground cable - connection

The ground cable must be mounted close to and parallel to the shielded coax cable thus minimizing ground loop problems. If possible, route the coax cable and the ground cable in metal conduits bonded to the hull or within a mast (depending on the actual installation).

The ground cable must be connected at one of the mounting/grounding bolts on the antenna. Use bolts and washers of stainless steel and seal the joint with protective coating to avoid corrosion. If the antenna is to be isolated from the mounting base, shoulder bushings and washers must be used - see page 165.

In the below drawing, vibration isolators are mounted.

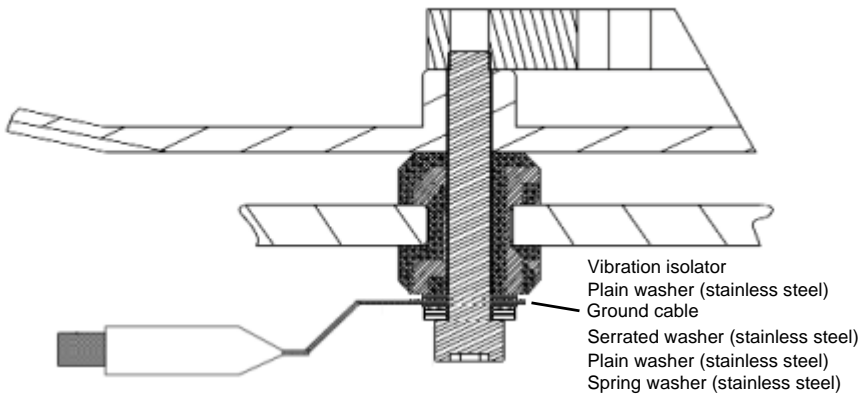

At the other end, connect the ground cable at the terminal grounding kit as described in *Grounding the terminal* on page 153.

C.9.3 Isolation of the antenna from the mounting base

In cases where the antenna is to be isolated from the mounting base, shoulder bushings and washers (accessories) must be used as illustrated below. Please note that the isolation has to be implemented on all four mounting bolts (including the bolt securing the ground cable).

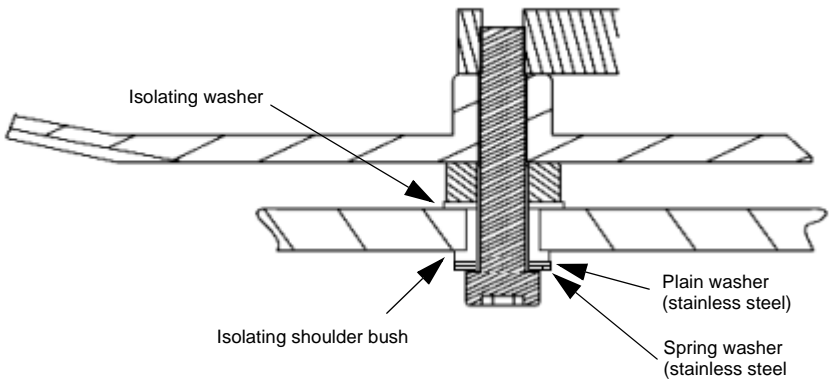

The ground cable must be connected at one of the mounting/grounding bolts on the antenna as illustrated below. Remember to seal the joint with protective coating to avoid corrosion.

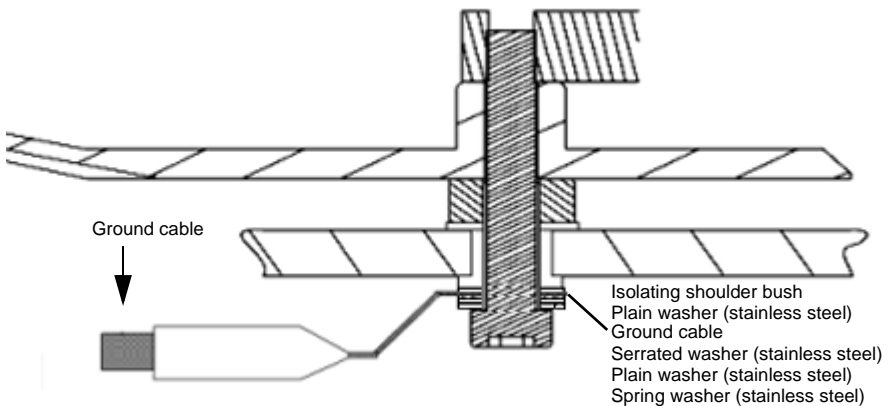

C.10 RF interference

Interference induced from nearby RF transmitters might cause system failures and in extreme cases permanent damage to the TracPhone equipment. If there are problems with interference from HF transmitters, it is advisable to mount ferrite clamps on the coax cable in order to provide suppression of induced RF. The ferrites will have no effect on the differential-mode signals but increases the impedance in relation to common-mode RFI.

C.10.1 Recommendations

Use 1-5 pcs. hinged clamp cores (e.g. the RFC or SFC series from Kitagawa) mounted on the antenna cable near the antenna.

C.11 Electrostatic Discharge

In addition to the RFI attenuation, mounting ferrite clamps on the antenna cable will also slow the fast rate-of-rise of an electrostatic discharge current pulse. This might be an issue during installation (antenna cable disconnected) where different electrical potentials have had the chance to build up between the terminal and antenna.

We recommend mounting 1-5 pcs. hinged clamp cores (e.g. the RFC or SFC series from Kitagawa) on the antenna cable near the antenna.

A

AMSL	Above Mean Sea Level
ATB	Antenna Tracking Board
ATM	Antenna Tracking Module
ATR	Antenna Tracking Receiver
AWG	American Wire Gauge. A means of specifying wire diameters.

B

BGAN	Broadband Global Area Network. A mobile satellite service that offers high-speed data up to 492 kbps and voice telephony. BGAN enables users to access e-mail, corporate networks and the Internet, transfer files and make telephone calls.
------	--

C

CM	Continuous Monitoring
----	-----------------------

D

DTMF	Dual Tone Multi Frequency. The keypad signaling technology that generates two distinct tones when each key is pressed. This system allows navigation of voice menus and other advanced calling services. All wireless phones use DTMF dialing.
------	--

E

EIRP	Effective Isotropically-Radiated Power. The amount of power that would have to be emitted by an isotropic antenna (that evenly distributes power in all directions) to produce the peak power density observed in the direction of maximum antenna gain.
------	--

ESD ElectroStatic Discharge

G

G/T A figure of merit of an antenna and low noise amplifier combination expressed in dB. "G" is the net gain of the system and "T" is the noise temperature of the system. The higher the number, the better the system.

GPIO General Purpose Input/Output

GPS Global Positioning System. A system of satellites, computers, and receivers that is able to determine the latitude and longitude of a receiver on Earth by calculating the time difference for signals from different satellites to reach the receiver.

H

HF High Frequency. The frequency band between 3 and 30 MHz. Used for medium and long range terrestrial radio communication.

HPA High Power Amplifier

I

I/O Input/Output

IMSO International Maritime Satellite Organisation. An intergovernmental body established to ensure that Inmarsat continues to meet its public service obligations, including obligations relating to the GMDSS.

IP Internet Protocol. The method or protocol by which data is sent from one computer to another on the Internet.

ISDN Integrated Services Digital Network. A circuit-switched telephone network system, designed to allow digital transmission of voice and data over ordinary telephone copper wires, resulting in higher quality and speed than are available with analog.

K

kbps kilobits per second

L

LAN Local Area Network

LNA Low Noise Amplifier

M

Mbps Megabit per second

P

PAST Person Activated Self Test. A test similar to the POST test, but activated by the user. The PAST causes the system to reset.

PC Personal Computer

PCB Printed Circuit Board

PIN Personal Identification Number. A secret numeric password shared between a user and a system, used to authenticate the user to the system.

PoE Power over Ethernet. A standard for combining power supply with transmission of data over the Ethernet. The source unit "injects" power into the Ethernet cable and the power is "picked up" at the connected device.

POST Power On Self Test. A test sequence that runs every time the system is powered up or reset.

PUK Pin Unlocking Key

R

RF Radio Frequency. Electromagnetic wave frequencies between about 3 kilohertz and about 300 gigahertz including the frequencies used for communications signals (radio, television, cell-phone and satellite transmissions) or radar signals.

RFI Radio Frequency Interference. A non-desired radio signal which creates noise or dropouts in the wireless system or noise in a sound system.

S

SIM Subscriber Identity Module. The SIM provides secure storing of the key identifying a mobile phone service subscriber but also subscription information, preferences and storage of text messages.

SMA SubMiniature version A. A coaxial RF connector developed as a minimal connector interface for coaxial cable with a screw type coupling mechanism. The connector has a 50 Ohm impedance.

SMA SubMiniature version A. SMA connectors are coaxial RF connectors developed as a minimal connector interface for coaxial cable with a screw type coupling mechanism. The connector has a 50 Ohm impedance.

SMS Short Message Service

SSB Single Side Band. A means of communications at sea. The range of SSB is up to several thousand miles and calls between yachts are free. Some stations allow telephone calls, email and some basic Internet services over SSB radio.

T

- TFTP** Trivial File Transfer Protocol. A very simple file transfer protocol, with the functionality of a very basic form of FTP. Since it is so simple, it is easy to implement in a very small amount of memory.
- TNC** Threaded Neill-Concelman. A type of RF connector used for terminating coaxial cables. The TNC connector is a threaded version of the BNC connector. The connector has a 50 Ohm impedance and operates best in the 0-11 GHz frequency spectrum.

U

- UDI** Unrestricted Digital Information. A transparent 64 kbps data channel.

A

- alarms, 118
- aluminum hulls
 - grounding, 157
- analog phone/fax interface, 65
- antenna
 - cables, 23
 - dimensions, 128, 137
 - drainage, 26
 - grounding, 23
 - grounding recommendations, 154
 - installation location, 8
 - installing, 23
 - interference, 10
 - isolation from mounting base, 165
 - mast design, 15
 - obstructions, 8
 - outline, 128, 137
 - radiation, 9
 - SAILOR 250 FleetBroadband, 4
 - SAILOR 500 FleetBroadband, 3
 - TT-3052A spare parts, 88
 - TT-3052B/C spare parts, 98
- Antenna Tracking Board
 - replacing in TT-3052A, 92
- Antenna Tracking Module
 - replacing in TT-3052B/C, 106
- Antenna Tracking Receiver
 - replacing in TT-3052B/C, 102

C

- cable support, 35, 36
- cable support for 19" rack, 43

- cables
 - antenna, 23
 - ground, 163
 - power, 48
- condensation in antenna, 26

D

- delivery
 - items included, 7
- diagnostic report, 120
- dimensions
 - 19" rack terminal, 146
 - antenna, 128, 137
 - flange, 131
 - terminal, 143
- discrete I/O interface, 71
- distance
 - antenna to GPS receiver, 14
 - antenna to radar, 11
 - antenna to transmitters, 138
 - between Inmarsat antennas, 13
- document number
 - this manual, i
- drainage of antenna, 26

E

- electrostatic discharge
 - recommendations, 166
- error messages, 118
- events
 - in LED panel, 118
 - logging, 120

F

- fiberglass hulls
 - grounding, 159
- flange
 - dimensions, 131
 - outline, 131

G

- GPS module
 - replacing in TT-3052A, 95
 - replacing in TT-3052B/C, 104
- GPS receiver
 - distance from antenna, 14
- grounding, 149
 - access, 30, 32
 - aluminum hulls, 157
 - antenna, 23, 154
 - cable, 163
 - fiberglass hulls, 159
 - recommendations, 153
 - steel hulls, 155
 - terminal, 153
 - timber hulls, 161
- grounding the terminal, 33, 42

H

- handset description, 5
- hardware interfaces, 59
- High Power Amplifier
 - replacing in TT-3052A, 89
 - replacing in TT-3052B/C, 99
- humidity in antenna, 26

I

- I/O interface, 71
- ignition function, 81
- indicators, function, 114
- installation
 - 19" terminal, 42
 - antenna, 23
 - terminal, 33
- interfaces on terminal
 - analog phone/fax interface, 65
 - antenna, 60
 - DC power input, 61
 - discrete I/O, 71
 - ISDN, 66
 - LAN, 68
 - L-Band, 76
 - overview, 59
 - terminal block for front switch, 64
- interference, 10
 - RF, 166
- IP handset
 - connecting, 70
 - entering PIN with, 83
 - short description, 5
- ISDN interface, 66
- items included in delivery, 7

L

- LAN interface, 68
- L-Band interface, 76
- light indicators, function, 114
- Low Noise Amplifier
 - replacing in TT-3052A, 92

M

- manual
 - document number, i
- mast for antenna, 15
- measuring source impedance, 48
- microwave radiation, iii
- modules, replacing in TT-3052A, 87
 - Antenna Tracking Board, 92
 - GPS module, 95
 - High Power Amplifier, 89
 - Low Noise Amplifier, 92
- modules, replacing in TT-3052B/C, 97
 - Antenna Tracking Module, 106
 - Antenna Tracking Receiver, 102
 - GPS module, 104
 - High Power Amplifier, 99

O

- obstructions
 - distance and size, 8
- outline
 - 19" rack terminal, 146
 - antenna, 128, 137
 - flange, 131
 - terminal, 143

P

- part numbers, 121
- Phone/Fax interface, 65
- PIN
 - entering in the web interface, 84
 - entering with a phone, 82
 - entering with IP handset, 83

- pin-out
 - analog phone/fax interface, 65
 - antenna interface, 60
 - DC power input, 62
 - discrete I/O interface, 72
 - ISDN interface, 67
 - LAN interface, 69
- placing the 19" rack terminal, 32
- placing the antenna, 8
- placing the terminal, 30
- PoE, 68
- pole mount, 15
- power
 - cable, 48
 - cable extension, 52
 - connecting, 54
 - connecting remote on/off, 57
 - sources, 47
 - switching on, 79
 - using remote on/off, 81
- power input on terminal, 61
- Power over Ethernet, 68
- PUK code, 83

R

- radar
 - distance from antenna, 11
- radiation, iii
- radiation level, 9
- remote on/off
 - connecting, 57
 - using, 81
- repair, 87
- reset button
 - accessing, 111
 - functions, 112

RF interference
recommendations, 166

S

safety summary, iii
service, 87
SIM card
inserting, 77
removing, 78
source impedance
measuring, 48
spare parts for TT-3052A antenna, 88
spare parts for TT-3052B/C antenna, 98
specifications, 123
steel hulls
grounding, 155
system units
IP handset, 5
SAILOR 250 FleetBroadband antenna,
4
SAILOR 500 FleetBroadband antenna,
3
terminal, 1

T

technical specifications, 123
antenna, 124
terminal, 139
temperature, 30
temperature, 19" rack terminal, 32

terminal
cable support, 36
cable support for 19" rack, 43
grounding, 33, 42
grounding recommendations, 153
installation location, 30
installation location, 19" rack, 32
installing, 33
installing 19" rack version, 42
introduction, 1
outline and dimensions, 143, 146
timber hulls
grounding, 161
tools for operation, 85
troubleshooting, 111
typography used in this manual, vii

U

unpacking, 7
user interfaces, 85

V

vibration, 27

98-125646-F