



Warranty Service Program
for
Thuraya XT & XT-DUAL

March 2012

1. Introduction

This document describes the End User Warranty, Level-1, Level-2 and Level-3 repair and the Warranty Procedure for Thuraya XT and Thuraya XT-DUAL phones.

The scope of this document extends to matters concerning the repair or replacement of defective Thuraya XT and XT-DUAL handset.

List of abbreviations used in this document:

CA	Cost Analysis
NTF	No Trouble Found
OBF	Out of Box Failure
ROC	Replace Only Center are Thuraya Service Partners that sell and distribute Thuraya products and services
TRC	Thuraya Repair Center operated by APSI in Dubai

2. Warranty

2.1. End User Warranty & Policy

- 12 months from date of sale (proof of purchase required), or
- Subject to detailed terms of the End User Warranty (refer to Appendix A)
Customers will be billed for any parts or labor charges not covered by the limited warranty.
- The End User Warranty shall become void for any of the following reasons, including, but not limited to:
 - Beyond one year warranty term
 - Serviced by anyone other than Thuraya or a Thuraya authorized service center
 - Failure or defects caused by misuse, abuse, accident, alteration or neglect
 - Unauthorized or improper installation, removal or repair
 - Failure to follow instructions
 - Spills of liquids or food
 - Normal wears and tears, i.e. scratches on antenna, plastics, etc.

2.2. Warranty Materials

Thuraya XT or Thuraya XT-DUAL Warranty Card (found in User Guide holder inside the phone package)

- At the point of purchase the dealer will complete the customer's warranty card with a signed and dated proof of sale stamp.
- This Warranty Card is only valid when all fields are fully filled by the dealer.
- Dealer must stick the detachable IMEI-label from the phone box on the Warranty Card.

Please note: warranty repair cannot be carried out without complete Warranty Card!

3. Repair Levels

3.1. Level-1 Repair

- Definition: Replacement of defective parts such as the battery, battery charger and/or other accessory parts without opening the Thuraya XT or XT-DUAL.
- Superficial check of the SIM, battery, battery charger and accessories.
- Removal and replacement of defective Level-1 parts can be accomplished without specialized technical training or know-how.
- The distribution partner requires no equipment. The handset shall not be opened.
- Download of new software release (at qualified locations). See Appendix B for software upgrade process and specifications.

3.2. Level-2 Easy Repair

- All Level-1 items.
- Disassembly and reassembly of terminal as required.
- Replacing damaged parts including the antenna, housing parts, the keypad, the display glass, the loudspeaker, the microphone and the pre-calibrated front PCB & main PCB unit.

3.3. Level-3 Component Level Repair

- All Level-2 items.
- Repair of defective PCBs down to the component level.

4. Repair Facilities

4.1. Thuraya Repair Center

The Thuraya Repair Center (TRC) is located in close proximity to the customer. TRC will perform the following services:

- Provide the warranty repair and return process
- Level-2 and Level-3 repairs.
- No trouble found (NTF) determination and reporting.
- Spare part inventory control.
- Repair reporting.
- Out of warranty repair support.

4.2. Certified Replace Only Center (ROC)

An ROC may be a retail point of sale or a designed location for customer service. These centers will require personnel who are familiar with the Thuraya system and Thuraya handset from an end user's operational point of view, especially with handset operation in the satellite mode. All Thuraya authorized Service Partners that will offer ROC services to end customers. The ROC works in conjunction with Thuraya Customer Care to provide direct end user support and guidance. ROC's will process Out of Box Failure (OBF) directly with TRC. End Users interface with the ROC for complain resolution, Level-1 warranty repairs and processing Level-2 and Level-3 repairs with TRC.

4.3. Replace Only Center Certification Process

- Thuraya will select service providers to be considered for registration as a ROC.
- ROC's may purchase a stock of Level-1 replacement parts (batteries, chargers) to support repair requirements. Replacement parts can also be merged with stock and sold to customers as accessories (ROC is responsible for maintaining appropriate inventory levels to support repair requirements). If the ROC does not desire to purchase the repair stock they will send defective Level-1 parts to TRC for replacement using the Warranty Repair process.

5. Warranty Procedures

5.1. Replace Only Center Repair Procedure

5.1.1. Warranty repairs:

- Verify customer complaint, if no trouble could be found, return the phone to the customer with a detailed explanation of proper use and operation of Thuraya phone and Thuraya system.
 - If the phone requires Level-1 repair:
 - ➔ Obtain customer's Warranty Card to verify in-warranty status.
 - ➔ If ROC has inventory of Level-1 replacement parts, replace the faulty level 1 parts, test phone and return to customer then send defective part to TRC for replacement (if applicable)
 - If the phone is determined to be beyond capability of Level-1 repair:
 - ➔ Obtain customer's Warranty Card to verify in-warranty status.
 - ➔ Send an e-mail to repaircenter@thuraya.com explaining the failure and including a telephone number for a call back.
 - ➔ Thuraya Product Support team will contact the ROC to verify the product failure and will then advise if the phone should be shipped to TRC.
 - ➔ If advised to ship the phone, prepare the "Repair Order" form.
 - ➔ On the repair order form give a detailed description of the failure (otherwise repair center will not be responsible for any delay).
 - ➔ Email the scanned repair order form(s) to the following email addresses and include it in the package together with the phone:
 - To: apsi@emirates.net.ae, jhchoi@emirates.net.ae
 - Copy: repaircenter@thuraya.com
 - ➔ Ship the phone to TRC as instructed, include warranty card, repair order form and clearly mark on the shipping form "Repair/Return" (see section 5.2)
 - ➔ ROC is responsible for maintaining shipping forms in case of lost equipment.
- TRC will repair and ship the unit within 5 working days of receipt ➔ If TRC tests the phone and find it to be an NTF, the ROC will be charged \$48 as NTF-fee plus round shipping costs.

5.1.2. Out of warranty repairs:

- Issues arising from abuse (e.g. beverage spills, tampering, unauthorized accessories, etc.) or which are obviously not repairable (e.g. fire, flood, physical damages, etc.) shall be handled at the ROC directly with the end user. In case such units would be sent to the repair center, the ROC would be charged with NTF fee plus shipping costs.
- Verify customer's complaint, if no trouble found, return phone to customer with a detailed explanation of proper use and operation of Thuraya XT Dual and Thuraya system.
- If the phone can be returned to service with a Level-1 repair:
 - ➔ Perform Level-1 repair in accordance with ROC's own policies and troubleshooting procedure – no TRC involvement required for out-of-warranty Level-1 repair.

- If the phone requires Level-2 or Level-3 repair:
 - ➔ Send an e-mail to repaircenter@thuraya.com explaining the failure and including a telephone number for a call back
 - ➔ Thuraya Product Support team will contact the ROC to verify the product failure and will then advise if the phone should be shipped to TRC.
 - ➔ If advised to ship the phone, prepare the "Repair Order" form..
 - ➔ On the repair order form give a detailed description of the failure (otherwise repair center will not be responsible for any delay).
 - ➔ Email the scanned repair order form(s) to the following email addresses and include it in the package together with the phone:
 - To: apsi@emirates.net.ae, jhchoi@emirates.net.ae
 - Copy: repaircenter@thuraya.com
 - ➔ Ship the phone to TRC as instructed, include warranty card, repair order form and clearly mark on the shipping form "Repair/Return" (see section 5.2)
 - ➔ Out of warranty repair shipping and related costs will be paid by the ROC.
 - ➔ TRC will perform an initial analysis of the phone and provide the ROC with repair estimate. For more serious repairs, the estimate may be for an initial evaluation only.
 - ➔ ROC is responsible for maintaining shipping forms in case of lost equipment.
 - ➔ ROC will provide TRC with repair authorization or phone disposition, there will be a minimum-processing fee charged for all out of warranty repairs.
 - ➔ Upon completion of repair, TRC will charge ROC for repairing cost as listed in Appendix C.
 - ➔ Upon receipt of payment from ROC TRC will return the required unit to ROC.
 - ➔ TRC will repair and ship the unit within 10 working days of CA approval.

5.2. Shipping Policy

When a defective in-warranty product needs to be returned to TRC, the ROC shall use TRC's contracted carrier, courier or freight forwarder. Method of shipment will be location dependent. The Thuraya XT or XT-DUAL phone must be wrapped in bubble pack and enclosed in a sturdy cardboard box for shipping. DO NOT USE the same phone box in which the phone was sold; it is not intended for individual shipment. Make sure the phone cannot move inside the shipping box.

On the shipping forms the type of export must be indicated as "Repair/Return". Check with TRC's contracted carrier, courier or freight forwarder before dispatching the units. This would prevent the ROC paying custom duty on the phone (exceeding custom charges will be charged back to the service provider).

5.3. No trouble found policy (NTF)

To control costs and encourage good customer service at the ROC, a no trouble found policy shall be enforced by TRC. When a product is returned as defective and yet no trouble is found after TRC evaluation, a fee plus shipping costs shall be levied against the ROC. This fee must be paid at the return of the product.

5.4. Out Of Box Failure (OBF) policy

Handsets found to be defective by ROC's or explicitly authorized agent during the initial sales process with the end user should always be discovered during the first test call made by the ROC before delivering the handset to the customer.

If the handset has more than a total of three hours of on-time, or if the customer has left the ROC's premises and subsequently return the handset due to a defect, the handset cannot be categorized as OBF and must be repaired following the end user warranty repair process. If the ROC or explicitly authorized agents claims OBF and the unit was not defected as OBF by the TRC, the phone will be considered as NTF, Cost Analysis (CA) will be created and charged to the ROC.

5.5. Out Of Box Failure (OBF) process

ROC's will follow the standard warranty return procedure for each OBF of a Thuraya XT or XT-DUAL.. OBF's shall be returned to TRC with the complete sales package including the phone, battery, travel charger and user manual in its original factory packaging. TRC shall replace the OBF unit within 5 days of receipt provided certain conditions are met. The OBF return must be complete, in as-new condition and have a verifiable failure. If an OBF unit does not meet these criteria it will be treated as if received under the standard after-sale service return procedure.

Appendix A

LIMITED WARRANTY

THURAYA XT and Thuraya XT-DUAL phones

This Limited Warranty is provided to the original end-user (The "Buyer") of any new Thuraya XT satellite phone or Thuraya XT-DUAL satellite & GSM phone. This Limited Warranty is non-transferable.

Warranty Coverage and Service

APSI warrants all new XT and XT-DUAL handsets (The "Product") under normal use and wear to be free from defects in material and workmanship for a period of one (1) year from the date of purchase by the end customer (the "Warranty Period"). If, under normal use and wear, the product becomes defective in materials or workmanship and is returned at Buyer's expense to an APSI authorized Service Center during the Warranty Period, the product will be repaired or replaced, at APSI's sole and exclusive option, and at no charge to the Buyer. The Buyer will be required to provide reasonable proof of date of purchase. Reconditioned replacement components, parts, units or materials may be used if the product is repaired or replaced. Costs incurred in the removal, de-installation or reinstallation of the product are not covered.

THIS LIMITED WARRANTY DOES NOT COVER AND APSI WILL NOT BE RESPONSIBLE FOR THE FOLLOWING:

This Limited Warranty will be void in its entirety if the product is serviced by anyone other than APSI or an APSI authorized Service Center. Buyer's sole and exclusive remedy shall be the repair or replacement of the defective Product, as specially described above. APSI neither assumes nor authorizes any authorized Service Center or any other entity to assume any other obligation or liability beyond that which is provided for in this Limited Warranty.

This Limited Warranty does not cover the following: products or accessory equipment not manufactured or provided by APSI; failures or defects caused by misuse, accident, alternation or neglect acts of God; spills of food or liquids; normal wear and tear; improper installation with other products or equipment nor manufactured or provided by APSI; payments for labor or service to representatives or service centers not authorized by APSI.

Since the satellite system and service on which this Product operators is provided by independent satellite carriers, APSI shall not be responsible for the operation, availability, coverage, range or grade of service provided by such service carriers.

Limitation of Liability

THIS LIMITED WARRANTY IS IN LIEU OF ALL OTHER WARRANTIES, WHETHER EXPRESS, IMPLIED OR STATUTORY, INCLUDING, WITHOUT LIMITATION, THE IMPLIED WARRANTIES OF MERCHANTABILITY AND FITNESS FOR A PARTICULAR PURPOSE. APSI SHALL NOT BE LIABLE FOR DAMAGES IN EXCESS OF THE PURCHASE PRICE OF THE PRODUCT, LESS REASONABLE AMOUNT FOR USE AND WEAR OR FOR ANY INCIDENTAL, SPECIAL, PUNITIVE OR CONSEQUENTIAL DAMAGES OF ANY NATURE WHATSOEVER, OR FOR ANY DELAYS, LOSS OF USE, TIME, PROFITS, REVENUE OR SAVINGS, ANY COMMERCIAL LOSS, INCONVENIENCE, MILEAGE, DAMAGE TO BUYER'S OR TO OTHER PERSON'S VEHICLE OR ANY OTHER PROPERTY, ARISING FROM THE USE OR INABILITY TO USE THE PRODUCT, OR OTHERWISE FOR ANY FAILURE TO PERFORM.

All liability and obligation of APSI under this Limited Warranty shall terminate upon the expiration of the applicable Warranty Period provided herein. This Limited Warranty sets forth the entire responsibility of APSI with respect to the Product. There are no other liabilities of APSI arising from the sale of the Product whether based on the warranty, contract, negligence or other theories of liability. In no event shall APSI's liability exceed the cost of correcting defects as provided herein.

This Limited Warranty gives specific legal rights to Buyer, and Buyer also may have other rights which may vary from jurisdiction to jurisdiction.

Customer Service
APSI (Asia Pacific Satellite-communications Inc.)
9FL, IT Castle 2-Dong, #550-1, Gasan-Dong,
Geumcheon-Gu, Seoul, KOREA

Appendix B

Field Software Upgrade Process

The software upgrade is similar to an internet upgrade process for PC applications. Thuraya authorized agents will download an executable program and run it under a MS Windows environment. The executable software can be downloaded manually through a browser. If no internet access is available, the upgrade can be distributed on CD-ROM. The USB data cable is distributed in the phone box together with the phone. To avoid unexpected power loss during the upgrade process, the battery charger is a standard component in the upgrade equipment. If, for any reason, the software upgrade process does not successfully complete, the emergency process must be strictly followed or critical data may be rendering the phone inoperable.

Required Equipment
USB data cable
Standard battery charger (AC Adaptor) found in the phone package
PC (Minimum Specifications): 700 MHz Pentium II processor Internet Access or CD-ROM Window 7 / Windows Vista / Windows XP

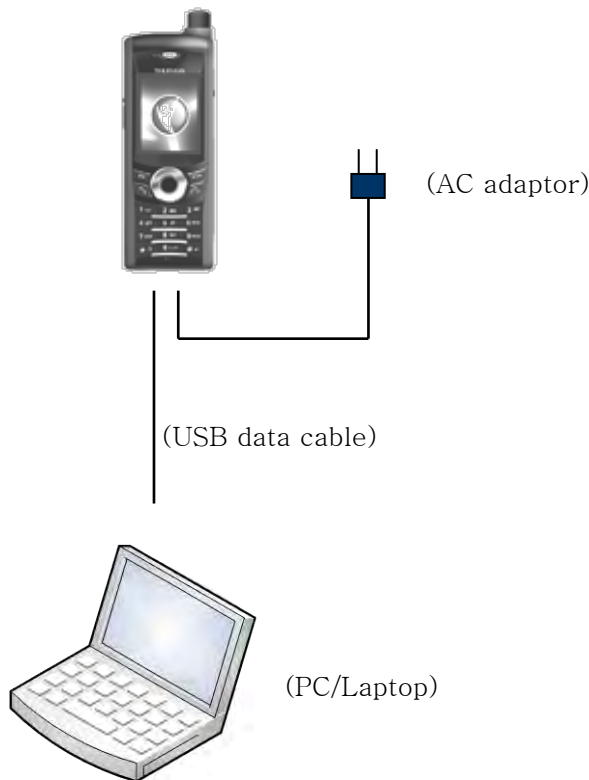

Appendix C

Out of Warranty Repair Price

C1) Out of Warranty Repair Price for **Thuraya XT**:

1) Parts Pricing

Parts Description	Unit Price (to SP)	R/ Level
Gift Box	\$6.50	Level 1
Blister Tray	\$2.50	Level 1
User Guide Holder	\$6.50	Level 1
User Guide Set (w/ QSG & Support-CD)	\$5.50	Level 1
Rear Antenna Rubber	\$1.50	Level 1
Ear-Set	\$20.00	Level 1
Spare Kit (set) : 10 pcs each in a kit	\$570.00	Level 2
LCD ass'y (Ready for replacing)	\$32.00	Level 3
Front PCB Ass'y	\$45.00	Level 3
Main PCB Ass'y	\$250.00	Level 3

2) Spare Kit Pricing.

Parts Description	Unit Price	Q'ty/Kit	Kit Price
Front Cover Ass'y w/ seaker & Keypad	\$17.00	10	\$170.00
Rear Cover Ass'y w/ antenna & side deco	\$40.00	10	\$400.00
Total 1 kit			\$570.00

3) Out Of Warranty repair cost.

Job Description	Cost details	Repair Level
SW Down Load Via USB	Labour Cost	1
Spare Kit repairing	Spare Kit cost + Labour cost + Shipping Cost	2
T-32 Down -Down Load	Labour + Shipping Cost	3
Components Level change on PCB	Based on Estimation	3
SVT (PXI)	Labour cost	3
Damaged Unit Desposition	\$40 + Shipping Cost	N/A

4) Post Warranty Fixed Labor cost.

Post Warranty Fixed labour Rates Pricing		
Repair Level	Labour Rate Price	Remarks
1	\$30	
2	\$35	IP543 regulation
3	\$53	IP543 regulation
NTF	\$48	No Trouble Found

C2) Out of Warranty Repair Price for **Thuraya XT-DUAL**:

1) Parts Pricing

Parts Description	Unit Price (to SP)	R/ Level
Gift Box	\$6.50	Level 1
Blister Tray	\$2.50	Level 1
User Guide Holder	\$6.50	Level 1
User Guide Set (w/ QSG & Support-CD)	\$5.50	Level 1
Rear Antenna Rubber	\$1.50	Level 1
Ear-Set	\$20.00	Level 1
Spare Kit (set) : 10 pcs each in a kit	\$570.00	Level 2
LCD ass'y (Ready for replacing)	\$54.00	Level 3
Front PCB Ass'y	\$65.00	Level 3
Main PCB Ass'y	\$320.00	Level 3

2) Spare Kit Pricing.

Parts Description	Unit Price	Q'ty/Kit	Kit Price
Front Cover Ass'y w/ seaker & Keypad	\$28.00	10	\$280.00
Rear Cover Ass'y w/ antenna & side deco	\$72.00	10	\$720.00
Total 1 kit			\$1,000.00

3) Out Of Warranty repair cost.

Job Description	Cost details	Repair Level
SW Down Load Via USB	Labour Cost	1
Spare Kit repairing	Spare Kit cost + Labour cost + Shipping Cost	2
T-32 Down -Down Load	Labour + Shipping Cost	3
Components Level change on PCB	Based on Estimation	3
SVT (PXI)	Labour cost	3
Damaged Unit Desposition	\$40 + Shipping Cost	N/A

4) Post Warranty Fixed Labor cost.

Post Warranty Fixed labour Rates Pricing		
Repair Level	Labour Rate Price	Remarks
1	\$37	
2	\$45	IP643 regulation
3	\$62	IP643 regulation
NTF	\$48	No Trouble Found

Appendix D

Contact address

Repair Center address:

APSI ME Gen. Trading LLC

(Thuraya Repair Center)

#209, Al-Huda Bldg, Garhoud

PO Box 123944, Dubai

United Arab Emirates

Telephone: +971-4-239 4877

Fax: +971-4-239 4878

E-mail: apsi@emirates.net.ae

DHL account number: 961094896

On the airwaybill form please include the following:

Receiver: "APSI ME Gen. Trading LLC"

Address: "Thuraya Repair Center" #209, Al-Huda Building, Garhoud, Dubai, UAE

Contact DHL as contracted carrier in your country before dispatching the units. This would prevent unnecessary delay in releasing units from the local customs. Shipments must include the correct shipping address otherwise the delivery will be delayed and the sender will be charged for shipment and any other related costs (e.g. customs).

This address shall only be used for repair of Thuraya SO-2510, Thuraya SG-2520, Thuraya XT and Thuraya XT-DUAL (otherwise the sender will be charged for shipment and any other related costs (e.g. customs) and the unit will be returned.

For complaints, questions or escalations please contact:

Thuraya Customer Care

Email: customer.care@thuraya.com, thurayarepairs@thuraya.com

Helpline: +97168080444/ +88216100100

Appendix E

Warranty card for warranty repair request

Date of Purchase: _____ Customer's name, address, country and telephone number: _____

THURAYA 

WARRANTY

This Warranty Card is only valid with all gaps filled in properly by dealer.

Place the detachable IMEI - label from the phone box here: _____ Dealer's stamp and signature: _____

Date of Purchase: *Sep. 1. 2009* Customer's name, address, country and telephone number: *Apsi, CHOI
UAE
04 3984798*

THURAYA 

WARRANTY

This Warranty Card is only valid with all gaps filled in properly by dealer.

Place the detachable IMEI - label from the phone box here: _____ Dealer's stamp and signature: _____

IMEI : 35601300 - 304605 - 2

Apsi